



ТЕХНИЧЕСКИЕ ДАННЫЕ

Рабочий диапазон: от 1 до 12 м³ / ч с головкой до 11 метров.
 Диапазон температур накачки жидкости: от -10 °С до + 110 °С.
 Перекачанная жидкость: чистая, свободная от твердых веществ и минеральных масел, не вязкая, химически нейтральная, близкая к характеристикам воды (макс. 30% гликоль).
 Максимальное рабочее давление: 10 бар (1000 кПа).
 Уровень защиты: IP 44
 Класс изоляции: F
 Кабельный втулка: PG 11
 Установка: с осью двигателя горизонталь.
 Стандартное входное напряжение: однофазное 230 В / 50 Гц

Трехфазная 400 В / 50 Гц

Этот продукт соответствует европейскому стандарту EN 60335-2-51

ПРИМЕНЕНИЕ

Насос для циркуляции горячей или холодной воды в системе центрального отопления в небольших общинах и системах кондиционирования воздуха как для гражданских и промышленных приложений, замкнутой замкнутой цепи и типа открытого цепи.

КОНСТРУКТИВНЫЕ ОСОБЕННОСТИ

Pump body in cast iron and motor in die cast aluminium.
 Impeller in technopolymer, motor shaft in hardened stainless steel held in graphite bearings lubricated by the pumping medium.
 Pump body with threaded ports.
 Rotor protective jacket, stator jacket, and closing flange in stainless steel.
 The two-pole asynchronous wet rotor motor features three-speed operation.
 Integral thermal probe in single-phase version.

MATERIALS

N.	PARTS	MATERIALS
1	PUMP BODY	CAST IRON
4	IMPELLER	TECHNOPOLYMER
7A	MOTOR SHAFT	STAINLESS STEEL
7B	ROTOR	-
8	STATOR	-
9	CAPACITOR	-
10	MOTOR CASING	DIE CAST ALUMINIUM
11	BREATHER PLUG	BRASS
100	TERMINAL BOX	-
127	SEAL RING	ETHYLENE PROPYLENE
128	STATOR JACKET	STAINLESS STEEL
129	ROTOR JACKET	STAINLESS STEEL
130	CLOSING FLANGE	STAINLESS STEEL
131	THRUST RING SUPPORT	ETHYLENE PROPYLENE
132	BUSHINGS	GRAPHITE
133	THRUST RING	CERAMIC

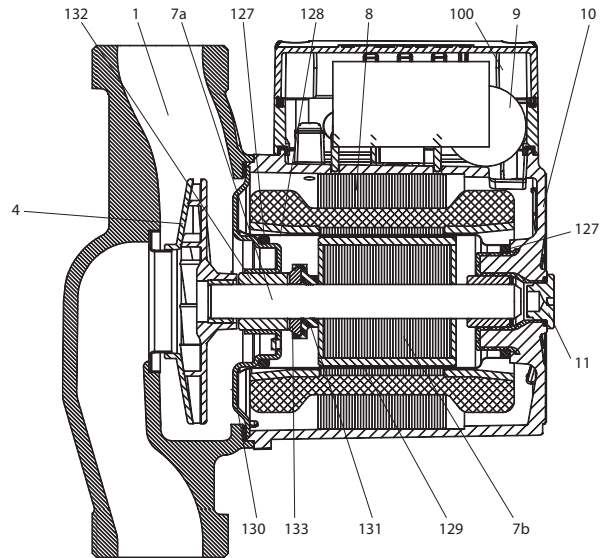

WET ROTOR CIRCULATORS

- Legend:
(example)

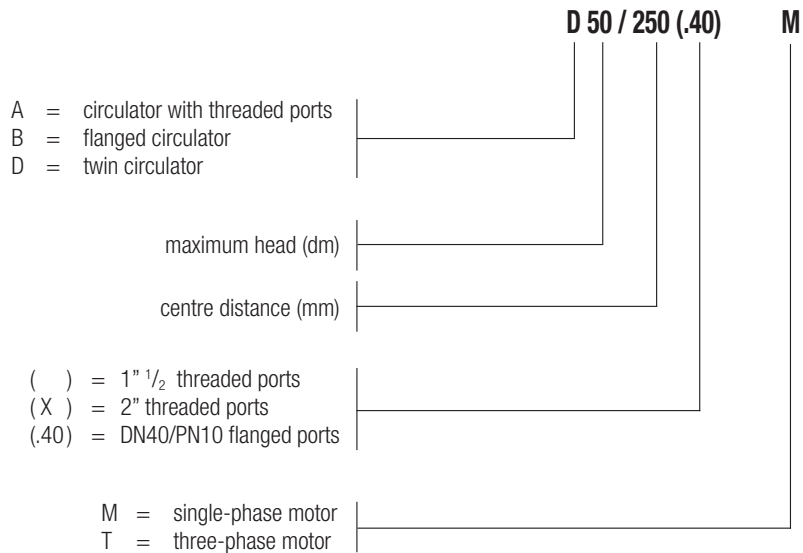

PERFORMANCE RANGE

The performance curves are based on kinematic viscosity values = 1 mm²/s and density equal to 1000 kg/m³. Curve tolerance according to ISO 9906.

GRAPHIC SELECTION TABLE

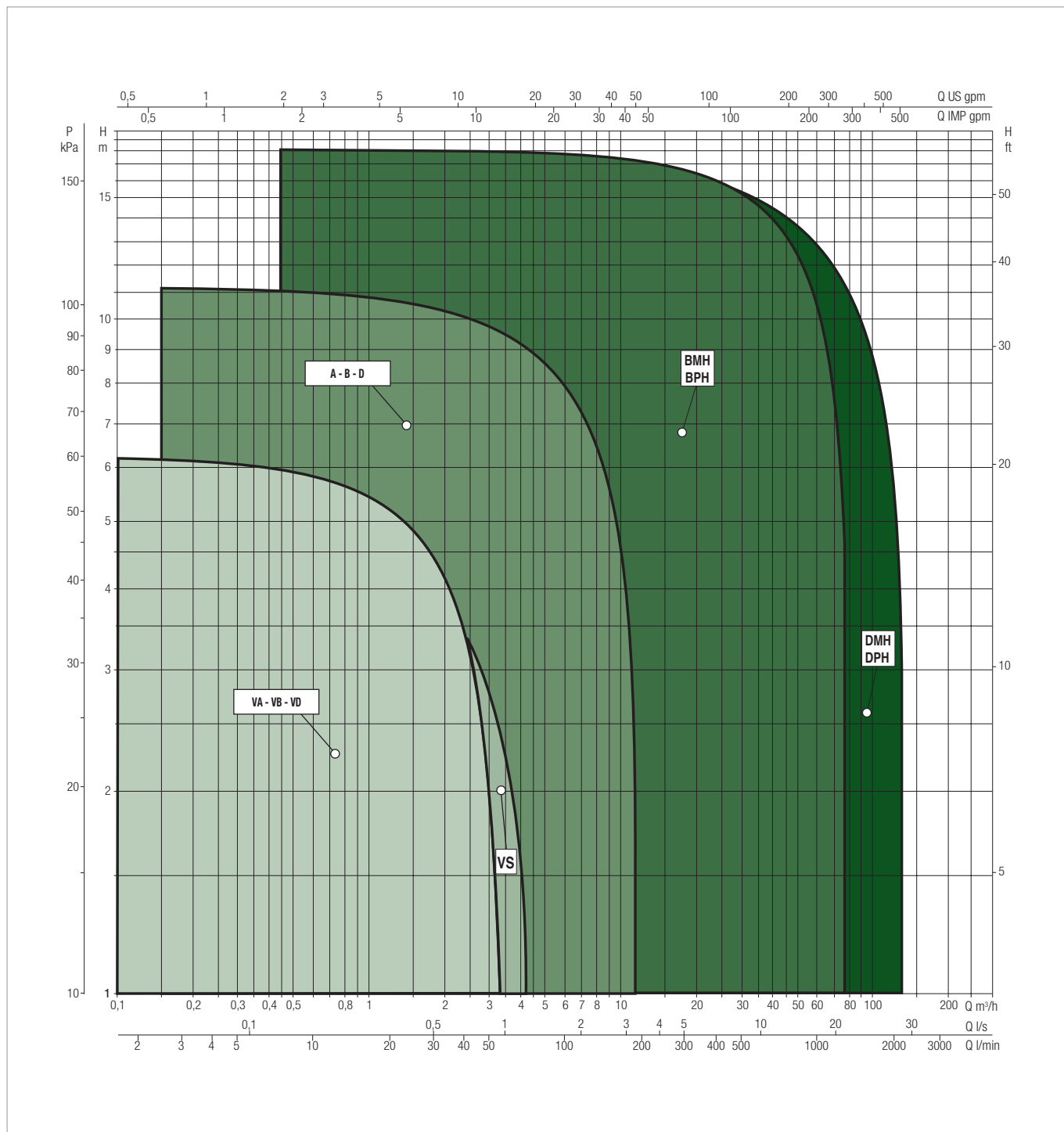

SELECTION TABLE - A SINGLE WITH UNIONS

MODEL	Q=m ³ /h	0	0,6	1,2	1,8	2,4	3	4,2	7,2	12
	Q=l/min	0	10	20	30	40	50	70	120	200
A 50/180 M	H (m)	5,7	5,6	5,4	5,3	5,1	4,8	4,2	2,6	
A 50/180 XM		5,7	5,6	5,4	5,3	5,1	4,8	4,2	2,6	
A 50/180 T		5,6	5,6	5,6	5,5	5,43	5,4	4,9	2,8	
A 50/180 XT		5,9	5,85	5,8	5,6	5,5	5,2	4,6	2,9	
A 56/180 M		6,35	6,3	6,2	6,18	6	5,9	5,5	4,2	1,2
A 56/180 XM		6,35	6,3	6,2	6,18	6	5,9	5,5	4,2	1,2
A 56/180 T		6,42	6,42	6,41	6,4	6,4	6,4	6,1	4,8	
A 56/180 XT		6,4	6,3	6,2	6,1	6	5,9	5,7	4,4	
A 80/180 M		8,25	8	7,6	7,4	7,2	6,9	6,3	3,8	
A 80/180 XM		8,25	8	7,6	7,4	7,2	6,9	6,3	3,8	
A 80/180 T		8,2	7,9	7,6	7,3	7	6,8	6,1	3,7	
A 80/180 XT		8,2	7,9	7,6	7,3	7	6,8	6,1	3,7	
A 110/180 M		11,3	11	10,8	10,5	10	9,8	8,9	6,7	
A 110/180 XM		11,3	11	10,8	10,5	10	9,8	9,2	7	1,7
A 110/180 T		11,3	11	10,8	10,5	10	9,8	8,9	6,6	
A 110/180 XT		11,3	11	10,8	10,5	10	9,8	9,2	7	1,6

SELECTION TABLE - B SINGLE WITH FLANGES

MODEL	Q=m ³ /h	0	0,6	1,2	1,8	2,4	3	4,2	7,2	12
	Q=l/min	0	10	20	30	40	50	70	120	200
B 50/250.40 M	H (m)	5,7	5,6	5,4	5,3	5,1	4,8	4,2	2,6	
B 50/250.40 T		5,9	5,85	5,8	5,6	5,5	5,2	4,6	2,9	
B 56/250.40 M		6,35	6,3	6,2	6,18	6	5,9	5,5	4,2	1,2
B 56/250.40 T		6,4	6,3	6,2	6,1	6	5,9	5,7	4,4	
B 80/250.40 M		8,25	8	7,6	7,4	7,2	6,9	6,3	3,8	
B 80/250.40 T		8,2	7,9	7,6	7,3	7	6,8	6,1	3,7	
B 110/250.40 M		11,3	11	10,8	10,5	10	9,8	9,2	7	1,7
B 110/250.40 T		11,3	11	10,8	10,5	10	9,8	9,2	7	1,6

SELECTION TABLE - D TWIN WITH FLANGES

MODEL	Q=m ³ /h	0	0,6	1,2	1,8	2,4	3	4,2	7,2	12
	Q=l/min	0	10	20	30	40	50	70	120	200
D 50/250.40 M	H (m)	5,7	5,6	5,4	5,3	5,1	4,8	4,2	2,6	
D 50/250.40 T		5,9	5,85	5,8	5,6	5,5	5,2	4,6	2,9	
D 56/250.40 M		6,35	6,3	6,2	6,18	6	5,9	5,5	4,2	1,2
D 56/250.40 T		5,9	5,85	5,8	5,6	5,5	5,2	4,6	2,9	
D 80/250.40 M		8,25	8	7,6	7,4	7,2	6,9	6,3	3,8	
D 80/250.40 T		8,2	7,9	7,6	7,3	7	6,8	6,1	3,7	
D 110/250.40 M		11,3	11	10,8	10,5	10	9,8	9,2	7	1,7
D 110/250.40 T		11,3	11	10,8	10,5	10	9,8	9,2	7	1,6

A 50/180 M - HEATING, AIR CONDITIONING

Pumped liquid temperature range: from -10 °C to +110 °C - Maximum operating pressure: 10 bar (1000 kPa)

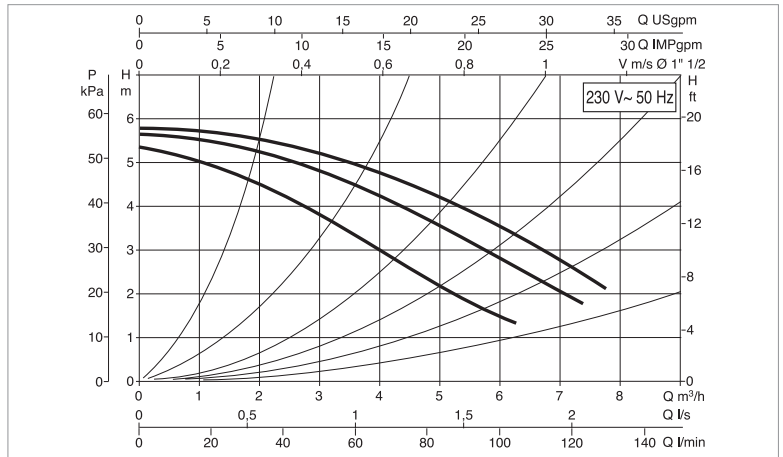
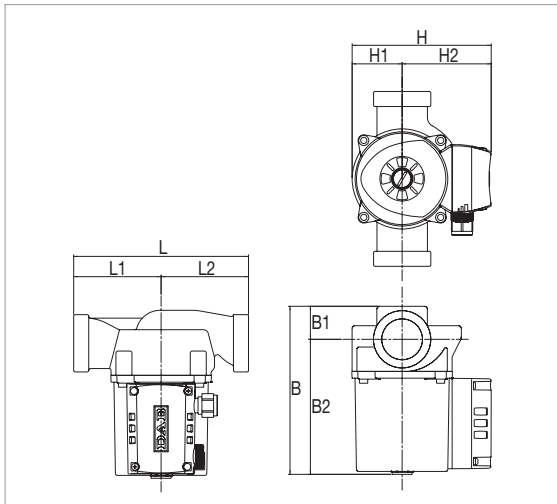

The performance curves are based on kinematic viscosity values = 1 mm²/s and density equal to 1000 kg/m³. Curve tolerance according to ISO 9906.

MODEL	CENTRE DISTANCE mm	POWER INPUT 50 Hz	UNIONS ON REQUEST	ELECTRICAL DATA						MINIMUM SUCTION PRESSURE	
				SPEED	REV. 1/min	P1 MAX W	In A	CAPACITOR		t°	90 °
								µF	Vc		
A 50/180 M	180	1x230 V ~	1"	3	2766	195	0,95	4	400	m.c.a.	1,5
				2	2616	194	0,95				
				1	2215	180	0,85				

MODEL	L	L1	L2	B	B1	B2	H	H1	H2	F	PACKING DIMENSIONS			VOLUME m ³	WEIGHT kg
											L	B	H		
A 50/180 M	180	90	90	173	34	139	143	52	92	1" 1/2	206	170	180	0,066	5

A 50/180 XM - HEATING, AIR CONDITIONING

Pumped liquid temperature range: from -10 °C to +110 °C - Maximum operating pressure: 10 bar (1000 kPa)

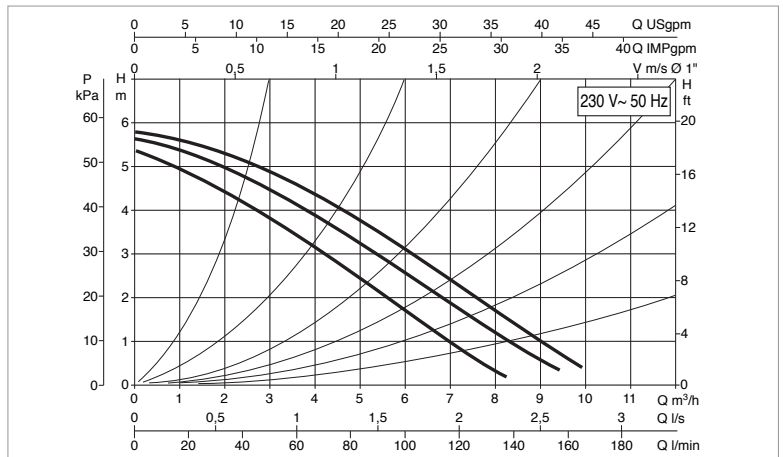
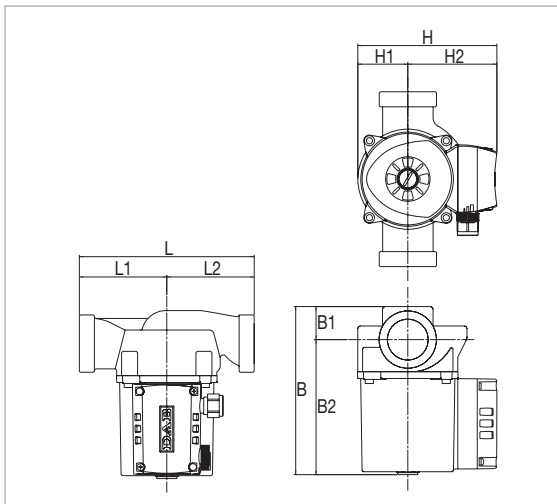

The performance curves are based on kinematic viscosity values = 1 mm²/s and density equal to 1000 kg/m³. Curve tolerance according to ISO 9906.

MODEL	CENTRE DISTANCE mm	POWER INPUT 50 Hz	UNIONS ON REQUEST	ELECTRICAL DATA						MINIMUM SUCTION PRESSURE	
				SPEED	REV. 1/min	P1 MAX W	In A	CAPACITOR		t°	90 °
								µF	Vc		
A 50/180 XM	180	1x230 V ~	1 1/2"	3	2791	184	0,92	4	400	m.c.a.	1,5
				2	2651	189	0,92				
				1	2297	168	0,80				

MODEL	L	L1	L2	B	B1	B2	H	H1	H2	F	PACKING DIMENSIONS			VOLUME m ³	WEIGHT kg
											L	B	H		
A 50/180 XM	180	90	90	173	34	139	143	52	92	2" G	206	170	180	0,066	5,3

A 50/180 T - HEATING, AIR CONDITIONING

Pumped liquid temperature range: from -10 °C to +110 °C - Maximum operating pressure: 10 bar (1000 kPa)

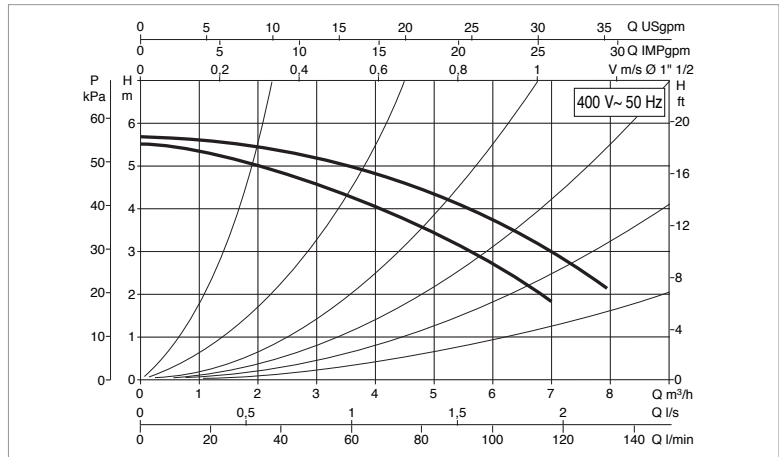
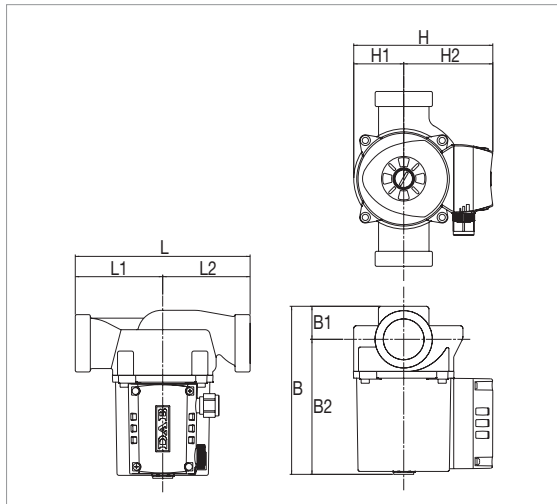

The performance curves are based on kinematic viscosity values = 1 mm²/s and density equal to 1000 kg/m³. Curve tolerance according to ISO 9906.

MODEL	CENTRE DISTANCE mm	POWER INPUT 50 Hz	UNIONS ON REQUEST	ELECTRICAL DATA						MINIMUM SUCTION PRESSURE	
				SPEED	REV. 1/min	P1 MAX W	In A	CAPACITOR		t°	90°
A 50/180 T	180	3x400 V ~	1"	2	2827	197	0,52	-	-	m.c.a.	1,5
				1	2502	139	0,25				

MODEL	L	L1	L2	B	B1	B2	H	H1	H2	F	PACKING DIMENSIONS			VOLUME m ³	WEIGHT kg
											L	B	H		
A 50/180 T	180	90	90	173	34	139	143	52	92	1 1/2	206	170	180	0,066	5,3

A 50/180 XT - HEATING, AIR CONDITIONING

Pumped liquid temperature range: from -10 °C to +110 °C - Maximum operating pressure: 10 bar (1000 kPa)

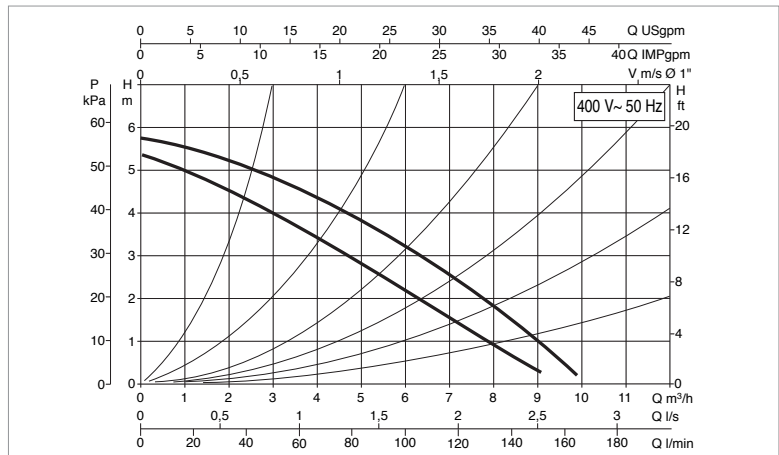
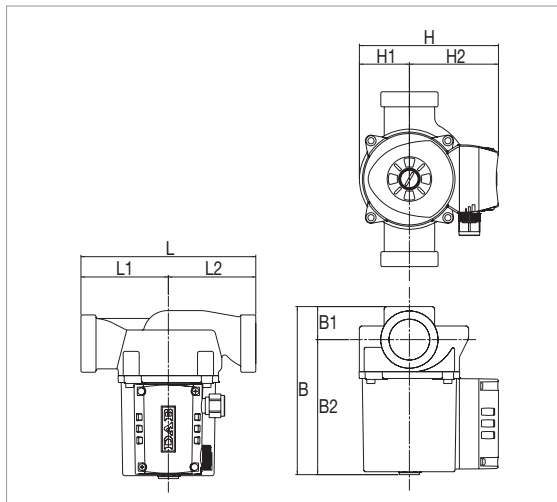

The performance curves are based on kinematic viscosity values = 1 mm²/s and density equal to 1000 kg/m³. Curve tolerance according to ISO 9906.

MODEL	CENTRE DISTANCE mm	POWER INPUT 50 Hz	UNIONS ON REQUEST	ELECTRICAL DATA						MINIMUM SUCTION PRESSURE	
				SPEED	REV. 1/min	P1 MAX W	In A	CAPACITOR		t°	90°
A 50/180 XT	180	3x400 V ~	1 1/4	2	2838	201	0,50	-	-	m.c.a.	1,5
				1	2520	129	0,23				

MODEL	L	L1	L2	B	B1	B2	H	H1	H2	F	PACKING DIMENSIONS			VOLUME m ³	WEIGHT kg
											L	B	H		
A 50/180 XT	180	90	90	173	34	139	143	52	92	2° G	206	170	180	0,066	5,2

A 56/180 M - HEATING, AIR CONDITIONING

Pumped liquid temperature range: from -10 °C to +110 °C - Maximum operating pressure: 10 bar (1000 kPa)

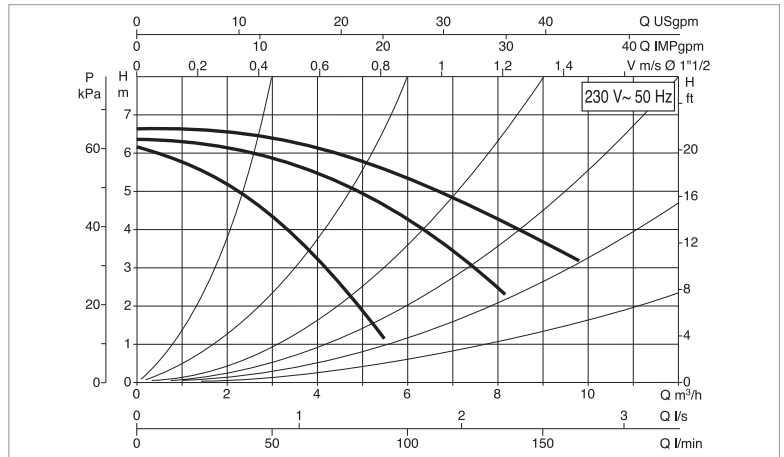
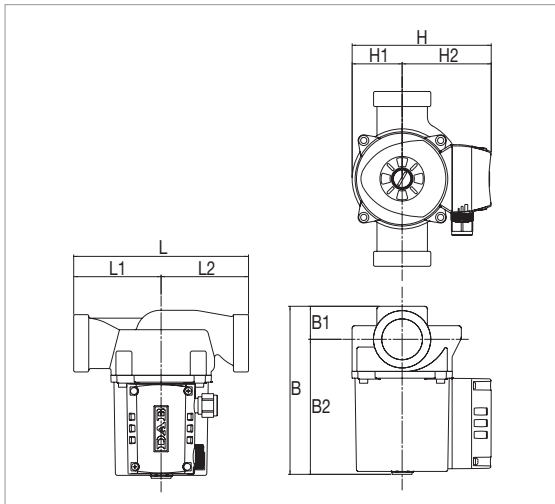

The performance curves are based on kinematic viscosity values = 1 mm²/s and density equal to 1000 kg/m³. Curve tolerance according to ISO 9906.

MODEL	CENTRE DISTANCE mm	POWER INPUT 50 Hz	UNIONS ON REQUEST	ELECTRICAL DATA						MINIMUM SUCTION PRESSURE	
				SPEED	REV. 1/min	P1 MAX W	In A	CAPACITOR		t°	90°
A 56/180 M	180	1x230 V ~	1"	3	2636	282	1,23	7	400	m.c.a.	1,5
				2	2226	287	1,30				
				1	1485	228	1,06				

MODEL	L	L1	L2	B	B1	B2	H	H1	H2	F	PACKING DIMENSIONS			VOLUME m ³	WEIGHT kg
											L	B	H		
A 56/180 M	180	90	90	173	34	139	143	52	92	1 1/2"	206	170	180	0,066	5,3

A 56/180 XM - HEATING, AIR CONDITIONING

Pumped liquid temperature range: from -10 °C to +110 °C - Maximum operating pressure: 10 bar (1000 kPa)

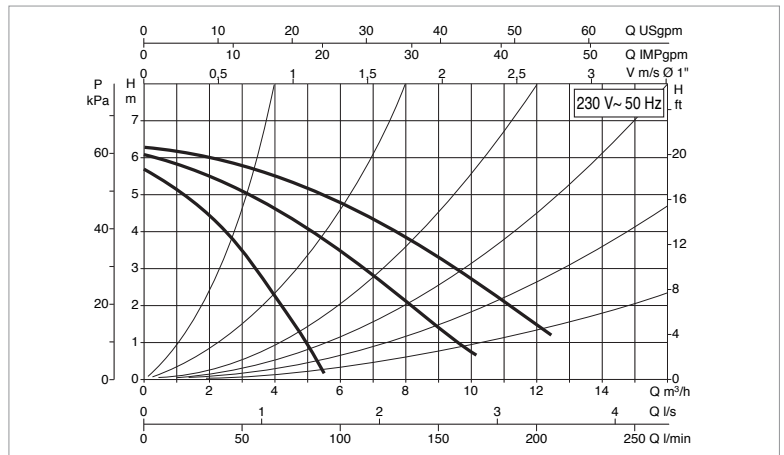
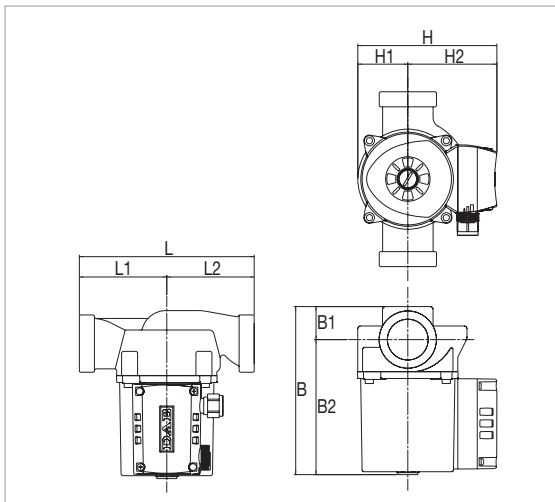

The performance curves are based on kinematic viscosity values = 1 mm²/s and density equal to 1000 kg/m³. Curve tolerance according to ISO 9906.

MODEL	CENTRE DISTANCE mm	POWER INPUT 50 Hz	UNIONS ON REQUEST	ELECTRICAL DATA						MINIMUM SUCTION PRESSURE	
				SPEED	REV. 1/min	P1 MAX W	In A	CAPACITOR		t°	90°
A 56/180 XM	180	1x230 V ~	1 1/4"	3	2658	271	1,18	7	400	m.c.a.	1,5
				2	2117	294	1,32				
				1	1394	224	1,00				

MODEL	L	L1	L2	B	B1	B2	H	H1	H2	F	PACKING DIMENSIONS			VOLUME m ³	WEIGHT kg
											L	B	H		
A 56/180 XM	180	90	90	173	34	139	143	52	92	2" G	206	170	180	0,066	5,3

A 56/180 T - HEATING, AIR CONDITIONING

Pumped liquid temperature range: from -10 °C to +110 °C - Maximum operating pressure: 10 bar (1000 kPa)

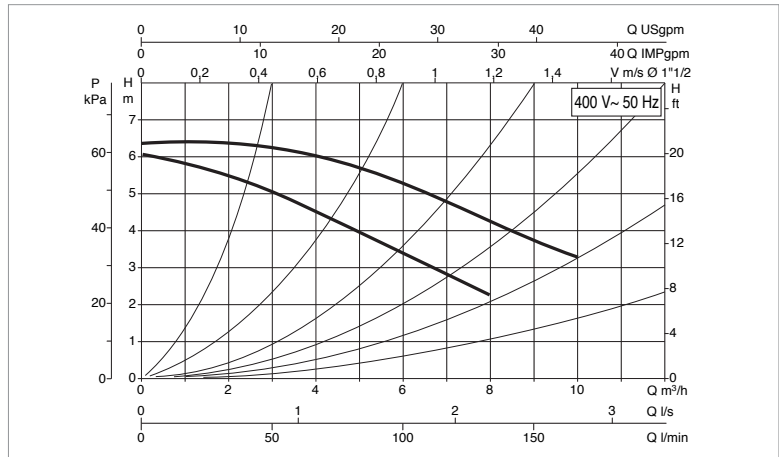
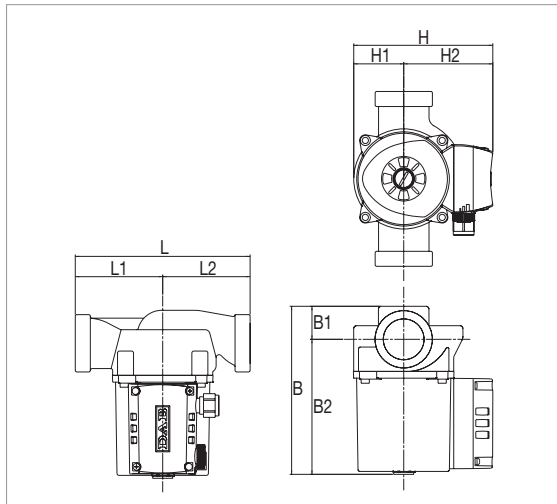

The performance curves are based on kinematic viscosity values = 1 mm²/s and density equal to 1000 kg/m³. Curve tolerance according to ISO 9906.

MODEL	CENTRE DISTANCE mm	POWER INPUT 50 Hz	UNIONS ON REQUEST	ELECTRICAL DATA						MINIMUM SUCTION PRESSURE	
				SPEED	REV. 1/min	P1 MAX W	In A	CAPACITOR		t°	90°
								μF	Vc		
A 56/180 T	180	3x400 V ~	1"	2 1	2704 2178	294 200	0,60 0,33	-	-	m.c.a.	1,5

MODEL	L	L1	L2	B	B1	B2	H	H1	H2	F	PACKING DIMENSIONS			VOLUME m³	WEIGHT kg
											L	B	H		
A 56/180 T	180	90	90	173	34	139	143	52	92	1" 1/2	206	170	180	0,066	5,2

A 56/180 XT - HEATING, AIR CONDITIONING

Pumped liquid temperature range: from -10 °C to +110 °C - Maximum operating pressure: 10 bar (1000 kPa)

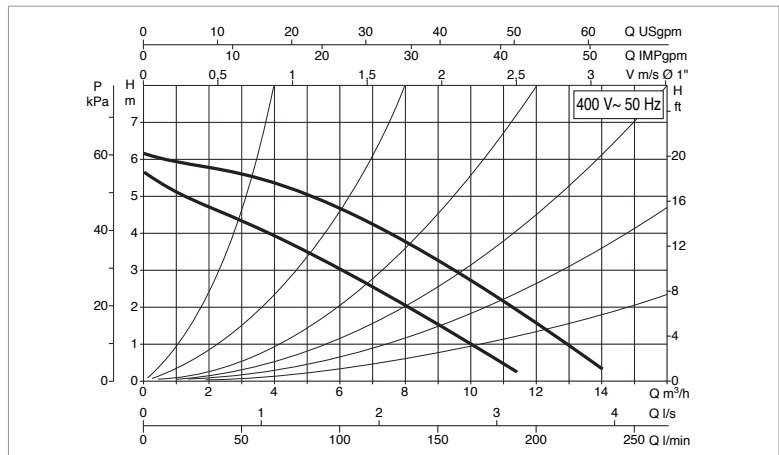
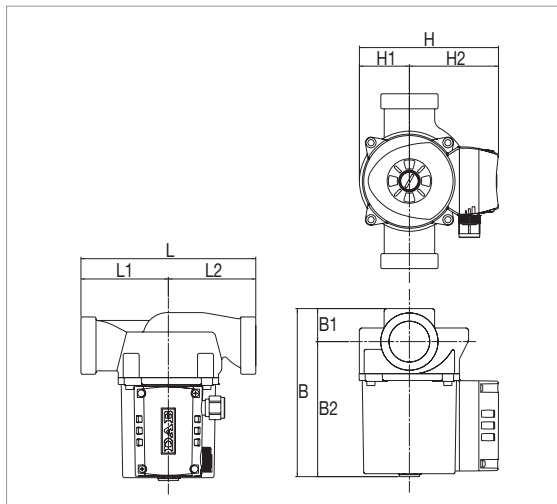

The performance curves are based on kinematic viscosity values = 1 mm²/s and density equal to 1000 kg/m³. Curve tolerance according to ISO 9906.

MODEL	CENTRE DISTANCE mm	POWER INPUT 50 Hz	UNIONS ON REQUEST	ELECTRICAL DATA						MINIMUM SUCTION PRESSURE	
				SPEED	REV. 1/min	P1 MAX W	In A	CAPACITOR		t°	90°
								μF	Vc		
A 56/180 XT	180	3x400 V ~	1" 1/4	2 1	2708 2178	291 200	0,60 0,32	-	-	m.c.a.	1,5

MODEL	L	L1	L2	B	B1	B2	H	H1	H2	F	PACKING DIMENSIONS			VOLUME m³	WEIGHT kg
											L	B	H		
A 56/180 XT	180	90	90	173	34	139	143	52	92	2" G	206	170	180	0,066	5,3

A 80/180 M - HEATING, AIR CONDITIONING

Pumped liquid temperature range: from -10 °C to +110 °C - Maximum operating pressure: 10 bar (1000 kPa)

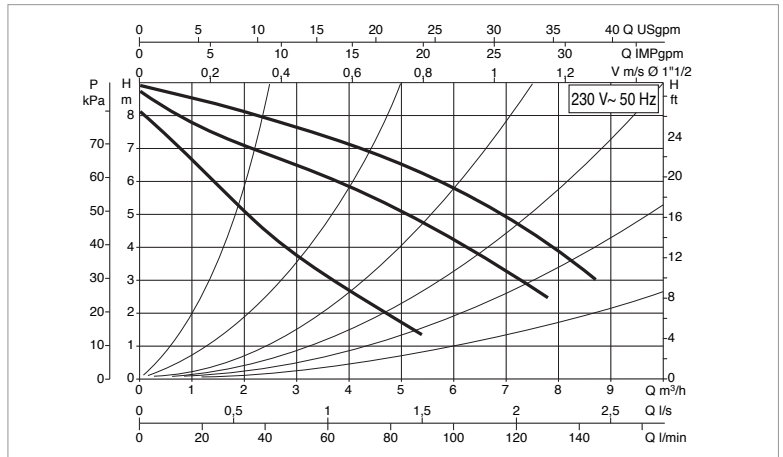
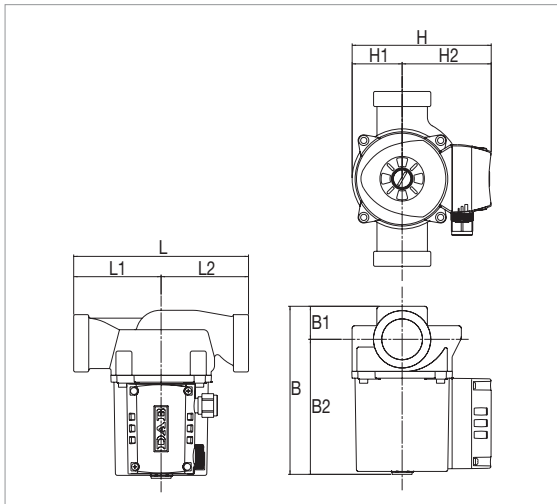

The performance curves are based on kinematic viscosity values = 1 mm²/s and density equal to 1000 kg/m³. Curve tolerance according to ISO 9906.

MODEL	CENTRE DISTANCE mm	POWER INPUT 50 Hz	UNIONS ON REQUEST	ELECTRICAL DATA						MINIMUM SUCTION PRESSURE	
				SPEED	REV. 1/min	P1 MAX W	In A	CAPACITOR		t°	90°
A 80/180 M	180	1x230 V ~	1"	3	2674	264	1,15	7	400	m.c.a.	2,5
				2	2356	262	1,20				
				1	1615	223	1,00				

MODEL	L	L1	L2	B	B1	B2	H	H1	H2	F	PACKING DIMENSIONS			VOLUME m ³	WEIGHT kg
											L	B	H		
A 80/180 M	180	90	90	173	34	139	143	52	92	1" 1/2	206	170	180	0,066	5,3

A 80/180 XM - HEATING, AIR CONDITIONING

Pumped liquid temperature range: from -10 °C to +110 °C - Maximum operating pressure: 10 bar (1000 kPa)

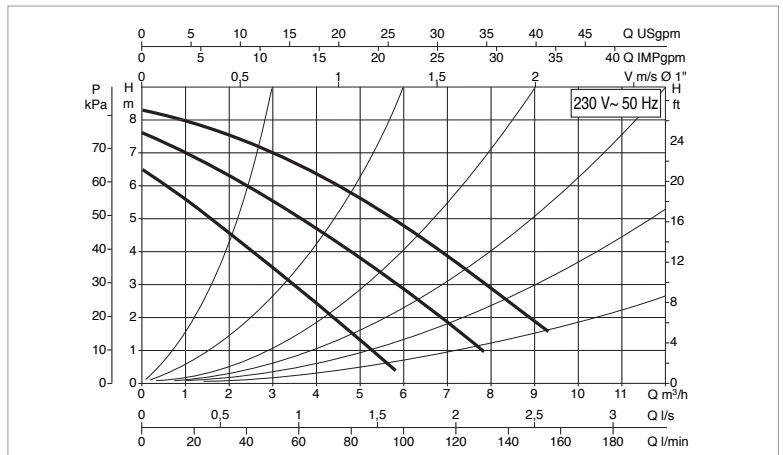
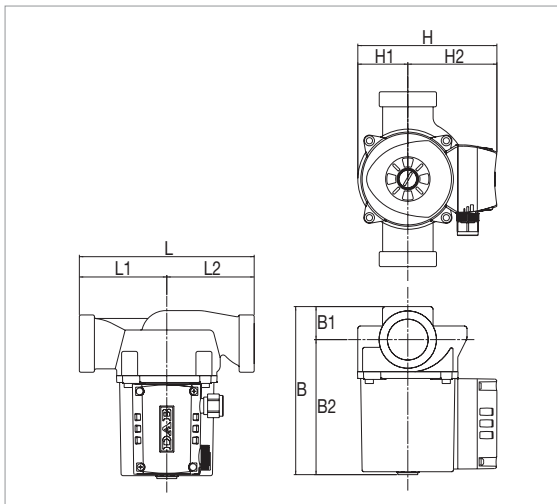

The performance curves are based on kinematic viscosity values = 1 mm²/s and density equal to 1000 kg/m³. Curve tolerance according to ISO 9906.

MODEL	CENTRE DISTANCE mm	POWER INPUT 50 Hz	UNIONS ON REQUEST	ELECTRICAL DATA						MINIMUM SUCTION PRESSURE	
				SPEED	REV. 1/min	P1 MAX W	In A	CAPACITOR		t°	90°
A 80/180 XM	180	1x230 V ~	1" 1/4	3	2683	256	1,12	7	400	m.c.a.	2,5
				2	2374	260	1,17				
				1	1688	218	1,00				

MODEL	L	L1	L2	B	B1	B2	H	H1	H2	F	PACKING DIMENSIONS			VOLUME m ³	WEIGHT kg
											L	B	H		
A 80/180 XM	180	90	90	173	34	139	143	52	92	2" G	206	170	180	0,066	5,2

A 80/180 T - HEATING, AIR CONDITIONING

Pumped liquid temperature range: from -10 °C to +110 °C - Maximum operating pressure: 10 bar (1000 kPa)

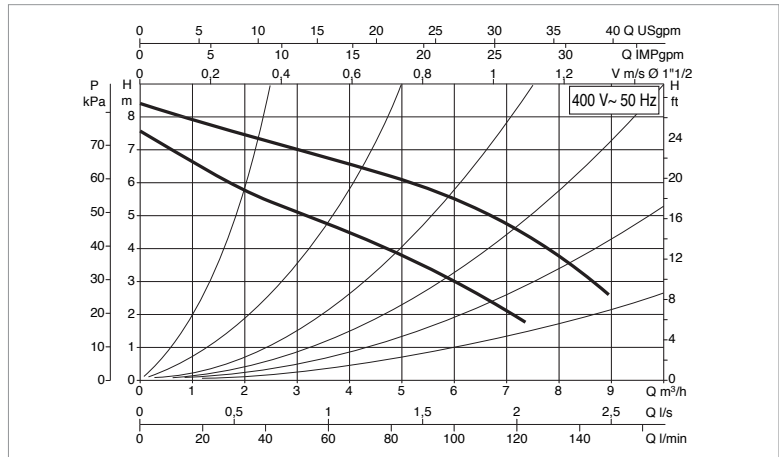
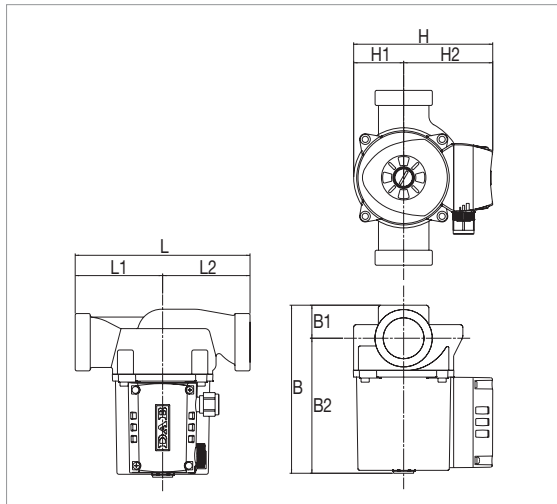

The performance curves are based on kinematic viscosity values = 1 mm²/s and density equal to 1000 kg/m³. Curve tolerance according to ISO 9906.

MODEL	CENTRE DISTANCE mm	POWER INPUT 50 Hz	UNIONS ON REQUEST	ELECTRICAL DATA						MINIMUM SUCTION PRESSURE	
				SPEED	REV. 1/min	P1 MAX W	In A	CAPACITOR		t°	90°
								µF	Vc		
A 80/180 T	180	3x400 V ~	1"	2	2724	271	0,57	-	-	m.c.a.	2,5
				1	2226	187	0,31				

MODEL	L	L1	L2	B	B1	B2	H	H1	H2	F	PACKING DIMENSIONS			VOLUME m³	WEIGHT kg
											L	B	H		
A 80/180 T	180	90	90	173	34	139	143	52	92	1" 1/2	206	170	180	0,066	5,3

A 80/180 XT - HEATING, AIR CONDITIONING

Pumped liquid temperature range: from -10 °C to +110 °C - Maximum operating pressure: 10 bar (1000 kPa)

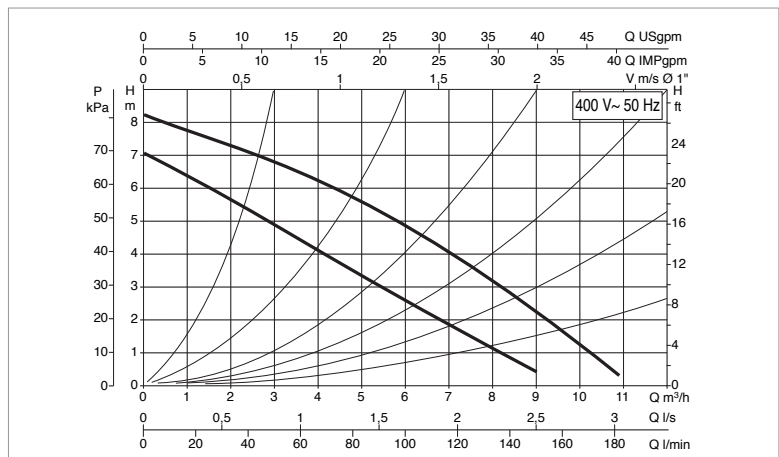
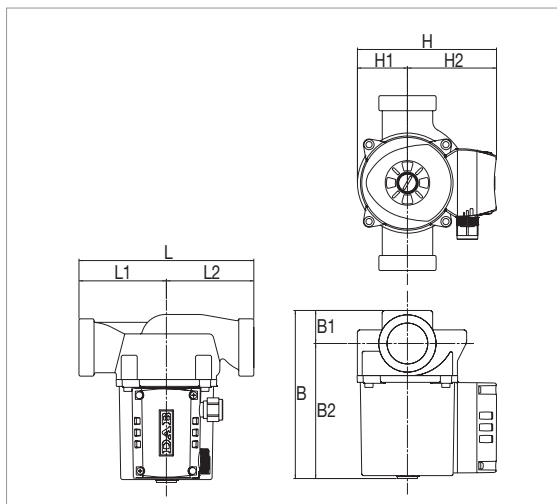

The performance curves are based on kinematic viscosity values = 1 mm²/s and density equal to 1000 kg/m³. Curve tolerance according to ISO 9906.

MODEL	CENTRE DISTANCE mm	POWER INPUT 50 Hz	UNIONS ON REQUEST	ELECTRICAL DATA						MINIMUM SUCTION PRESSURE	
				SPEED	REV. 1/min	P1 MAX W	In A	CAPACITOR		t°	90°
								µF	Vc		
A 80/180 XT	180	3x400 V ~	1"	2	2727	272	0,57	-	-	m.c.a.	2,5
				1	2227	186	0,30				

MODEL	L	L1	L2	B	B1	B2	H	H1	H2	F	PACKING DIMENSIONS			VOLUME m³	WEIGHT kg
											L	B	H		
A 80/180 XT	180	90	90	173	34	139	143	52	92	2" G	206	170	180	0,066	5,3

A 110/180 M - HEATING, AIR CONDITIONING

Pumped liquid temperature range: from -10 °C to +110 °C - Maximum operating pressure: 10 bar (1000 kPa)

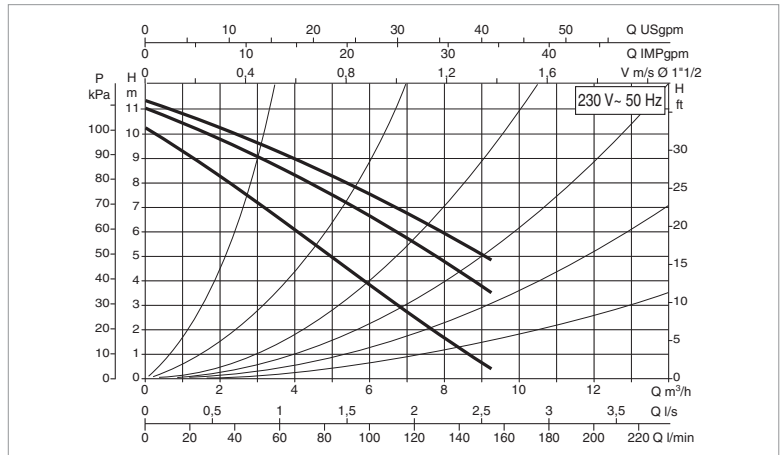
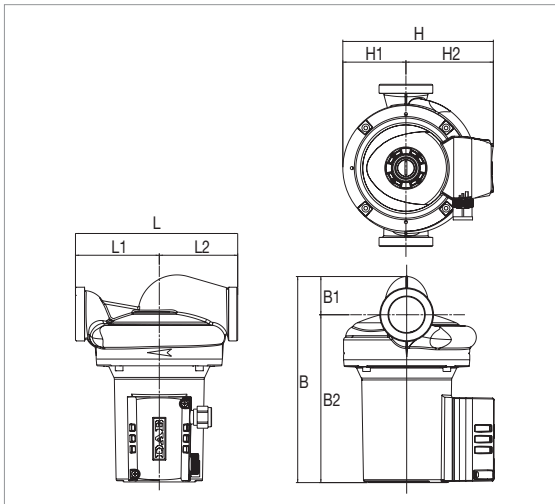

The performance curves are based on kinematic viscosity values = 1 mm²/s and density equal to 1000 kg/m³. Curve tolerance according to ISO 9906.

MODEL	CENTRE DISTANCE mm	POWER INPUT 50 Hz	UNIONS ON REQUEST	ELECTRICAL DATA						MINIMUM SUCTION PRESSURE	
				SPEED	REV. 1/min	P1 MAX W	In A	CAPACITOR		t°	90°
								µF	Vc		
A 110/180 M	180	1x230 V ~	2" G	3	2746	410	1,6	12	450	m.c.a.	2,5
				2	2552	393	1,8				
				1	2052	361	1,7				

MODEL	L	L1	L2	B	B1	B2	H	H1	H2	F	PACKING DIMENSIONS			VOLUME m ³	WEIGHT kg
											L	B	H		
A 110/180 M	180	93	87	229	42	186	167	70	97	1" 1/2 G	237	200	272	0,066	5,3

A 110/180 XM - HEATING, AIR CONDITIONING

Pumped liquid temperature range: from -10 °C to +110 °C - Maximum operating pressure: 10 bar (1000 kPa)

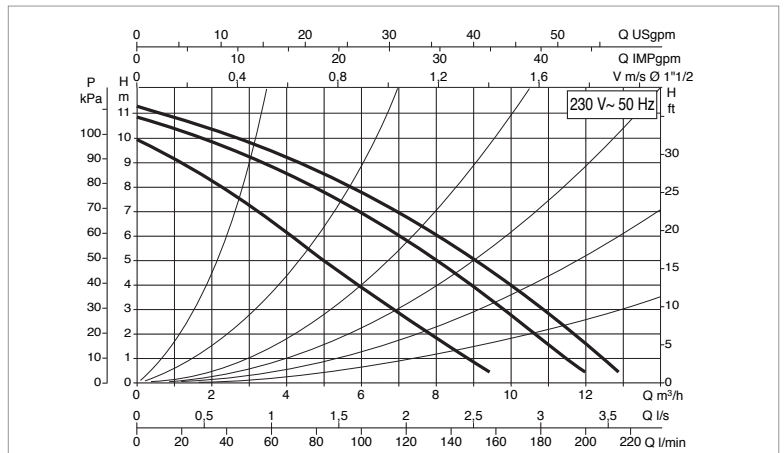
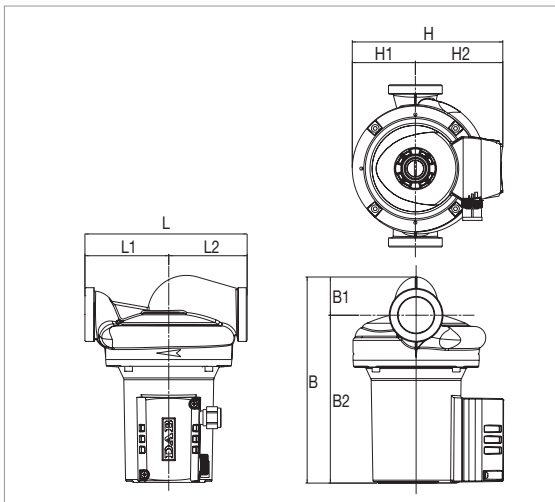

The performance curves are based on kinematic viscosity values = 1 mm²/s and density equal to 1000 kg/m³. Curve tolerance according to ISO 9906.

MODEL	CENTRE DISTANCE mm	POWER INPUT 50 Hz	UNIONS ON REQUEST	ELECTRICAL DATA						MINIMUM SUCTION PRESSURE	
				SPEED	REV. 1/min	P1 MAX W	In A	CAPACITOR		t°	90°
								µF	Vc		
A 110/180 XM	180	1x230 V ~	1" 1/4	3	2746	195	410	12	450	m.c.a.	2,5
				2	2552	194	393				
				1	2052	180	361				

MODEL	L	L1	L2	B	B1	B2	H	H1	H2	F	PACKING DIMENSIONS			VOLUME m ³	WEIGHT kg
											L	B	H		
A 110/180 XM	180	93	87	229	42	186	167	70	97	2" G	237	200	272	0,066	5,3

A 110/180 T - HEATING, AIR CONDITIONING

Pumped liquid temperature range: from -10 °C to +110 °C - Maximum operating pressure: 10 bar (1000 kPa)

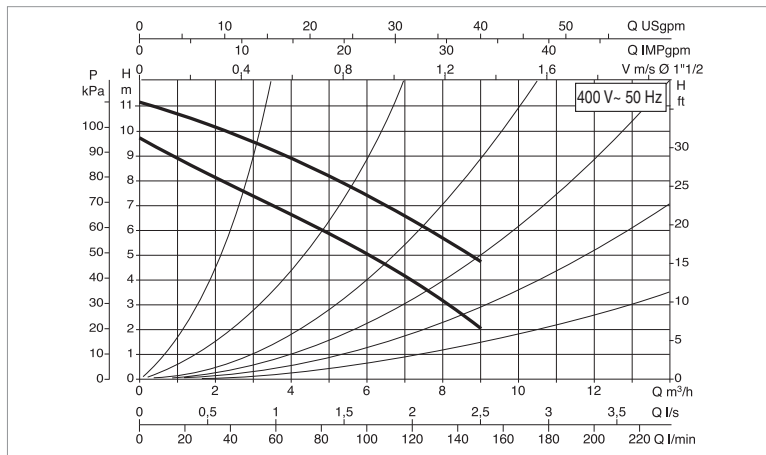
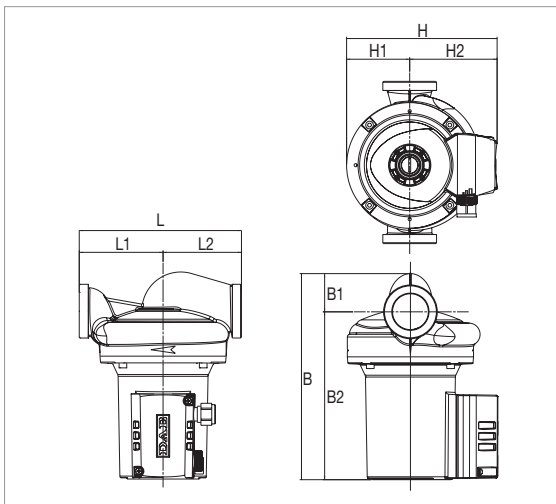

The performance curves are based on kinematic viscosity values = 1 mm²/s and density equal to 1000 kg/m³. Curve tolerance according to ISO 9906.

MODEL	CENTRE DISTANCE mm	POWER INPUT 50 Hz	UNIONS ON REQUEST	ELECTRICAL DATA						MINIMUM SUCTION PRESSURE	
				SPEED	REV. 1/min	P1 MAX W	In A	CAPACITOR		t°	90°
A 110/180 T	180	3x400 V ~	2° G	2	2753	402	0,87	-	-	m.c.a.	2,5
				1	2338	286	0,48				

MODEL	L	L1	L2	B	B1	B2	H	H1	H2	F	PACKING DIMENSIONS			VOLUME m ³	WEIGHT kg
											L	B	H		
A 110/180 T	180	93	87	229	186	42	163	70	93	1 1/2° G	237	200	272	0,066	5,2

A 110/180 XT - HEATING, AIR CONDITIONING

Pumped liquid temperature range: from -10 °C to +110 °C - Maximum operating pressure: 10 bar (1000 kPa)

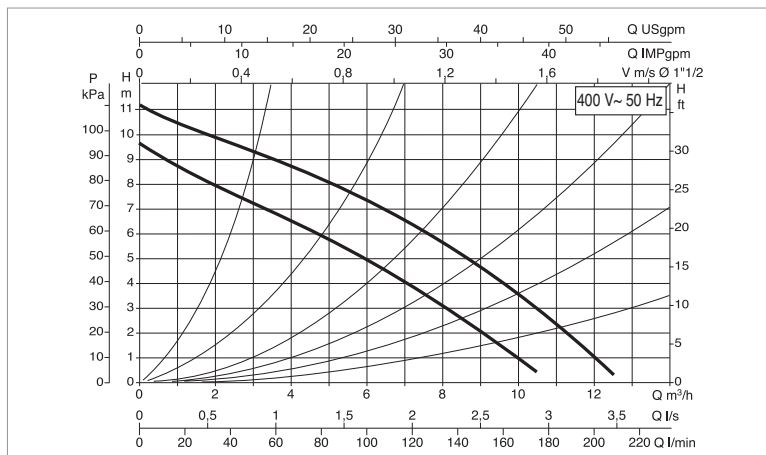
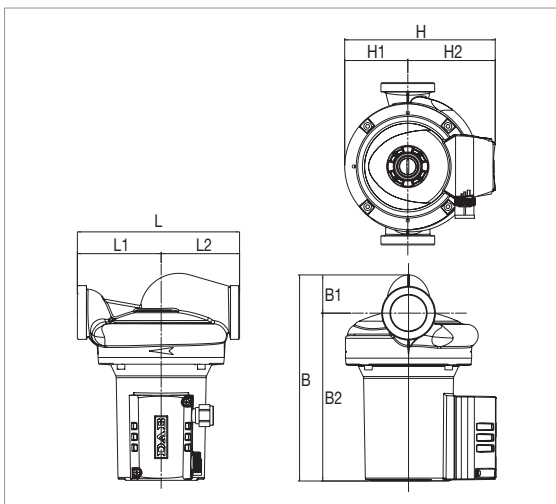

The performance curves are based on kinematic viscosity values = 1 mm²/s and density equal to 1000 kg/m³. Curve tolerance according to ISO 9906.

MODEL	CENTRE DISTANCE mm	POWER INPUT 50 Hz	UNIONS ON REQUEST	ELECTRICAL DATA						MINIMUM SUCTION PRESSURE	
				SPEED	REV. 1/min	P1 MAX W	In A	CAPACITOR		t°	90°
A 110/180 XT	180	3x400 V ~	2° G	2	2759	403	0,90	-	-	m.c.a.	2,5
				1	2341	289	0,48				

MODEL	L	L1	L2	B	B1	B2	H	H1	H2	F	PACKING DIMENSIONS			VOLUME m ³	WEIGHT kg
											L	B	H		
A 110/180 XT	180	93	87	229	186	42	163	70	93	2° G	237	200	272	0,066	5,2

B 50/250.40 M - HEATING, AIR CONDITIONING

Pumped liquid temperature range: from -10 °C to +110 °C - Maximum operating pressure: 10 bar (1000 kPa)

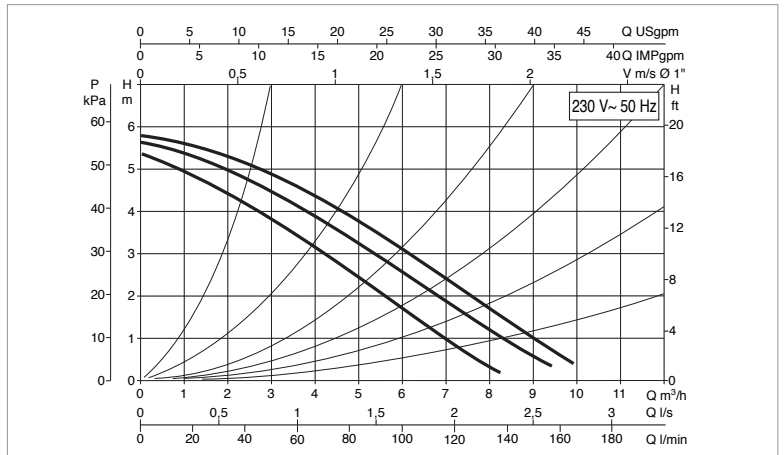
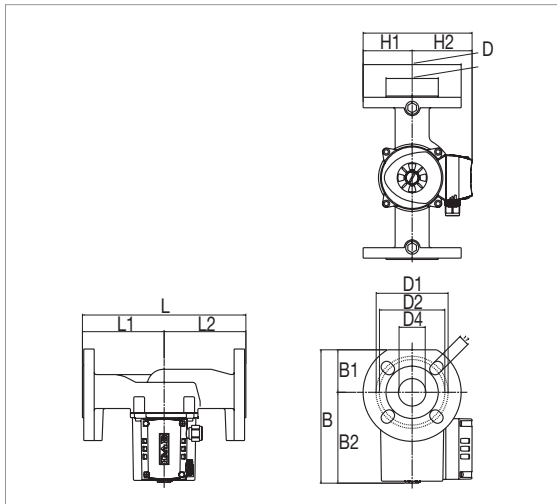

The performance curves are based on kinematic viscosity values = 1 mm²/s and density equal to 1000 kg/m³. Curve tolerance according to ISO 9906.

MODEL	CENTRE DISTANCE mm	POWER INPUT 50 Hz	UNIONS ON REQUEST	ELECTRICAL DATA						MINIMUM SUCTION PRESSURE	
				SPEED	REV. 1/min	P1 MAX W	In A	CAPACITOR		t°	90 °
B 50/250.40 M	250	1x230 V ~	DN 40	3	2766	195	0,95	4	400	m.c.a.	1,5
				2	2616	194	0,95				
				1	2215	180	0,85				

MODEL	L	L1	L2	B	B1	B2	D	D1	D2	D3	D4	H	H1	H2	F	PACKING DIMENSIONS			VOLUME m ³	WEIGHT kg
																L	B	H		
B 50/250.40 M	250	125	125	204	65	139	150	110	100	80	40	167	75	92	DN40/PN10	302	202	283	0,013	9,1

B 50/250.40 T - HEATING, AIR CONDITIONING

Pumped liquid temperature range: from -10 °C to +110 °C - Maximum operating pressure: 10 bar (1000 kPa)

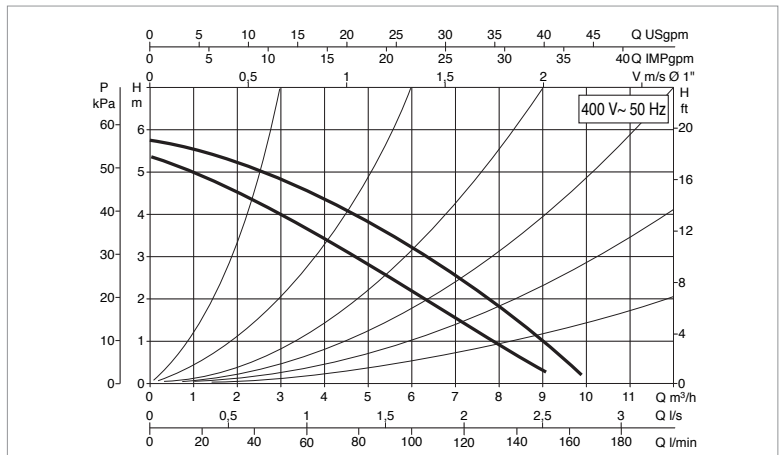
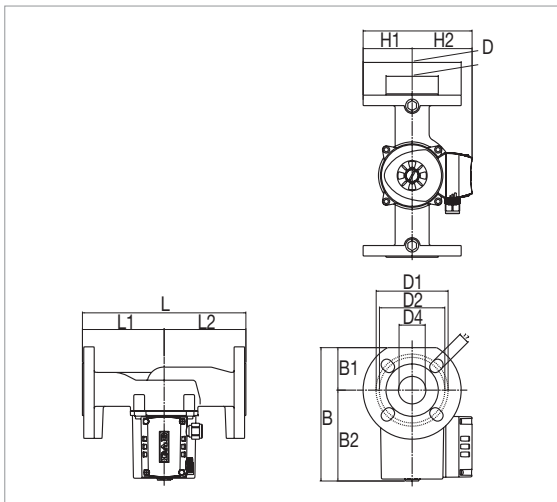

The performance curves are based on kinematic viscosity values = 1 mm²/s and density equal to 1000 kg/m³. Curve tolerance according to ISO 9906.

MODEL	CENTRE DISTANCE mm	POWER INPUT 50 Hz	UNIONS ON REQUEST	ELECTRICAL DATA						MINIMUM SUCTION PRESSURE	
				SPEED	REV. 1/min	P1 MAX W	In A	CAPACITOR		t°	90 °
B 50/250.40 T	250	3x400 V ~	DN 40	2	2838	201	0,5	-	-	m.c.a.	1,5
				1	2520	129	0,23				

MODEL	L	L1	L2	B	B1	B2	D	D1	D2	D3	D4	H	H1	H2	F	PACKING DIMENSIONS			VOLUME m ³	WEIGHT kg
																L	B	H		
B 50/250.40 T	250	125	125	204	65	139	150	110	100	80	40	167	75	92	DN40/PN10	302	202	283	0,013	9,3

B 56/250.40 M - HEATING, AIR CONDITIONING

Pumped liquid temperature range: from -10 °C to +110 °C - Maximum operating pressure: 10 bar (1000 kPa)

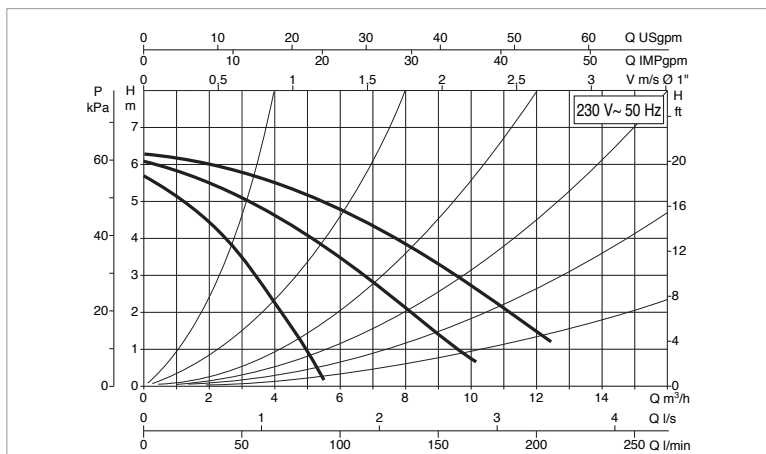
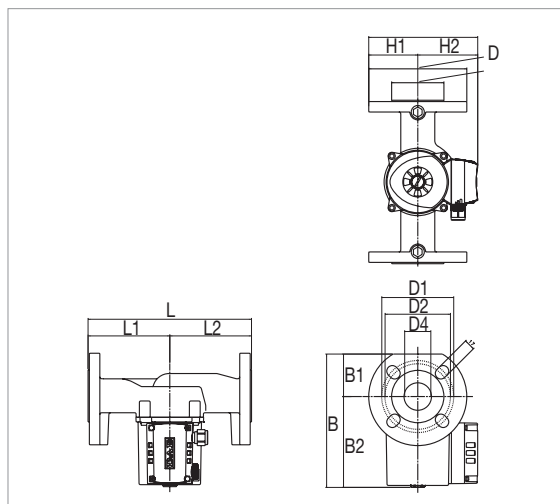

The performance curves are based on kinematic viscosity values = 1 mm²/s and density equal to 1000 kg/m³. Curve tolerance according to ISO 9906.

MODEL	CENTRE DISTANCE mm	POWER INPUT 50 Hz	UNIONS ON REQUEST	ELECTRICAL DATA						MINIMUM SUCTION PRESSURE	
				SPEED	REV. 1/min	P1 MAX W	In A	CAPACITOR		t°	90°
B 56/250.40 M	250	1x230 V ~	DN 40	3	2658	271	1,18	7	400	m.c.a.	1,5
				2	2117	294	1,32				
				1	1394	224	1				

MODEL	L	L1	L2	B	B1	B2	D	D1	D2	D3	D4	H	H1	H2	F	PACKING DIMENSIONS			VOLUME m ³	WEIGHT kg
																L	B	H		
B 56/250.40 M	250	125	125	204	65	139	150	110	100	80	40	167	75	92	DN40/PN10	302	202	283	0,013	9,3

B 56/250.40 T - HEATING, AIR CONDITIONING

Pumped liquid temperature range: from -10 °C to +110 °C - Maximum operating pressure: 10 bar (1000 kPa)

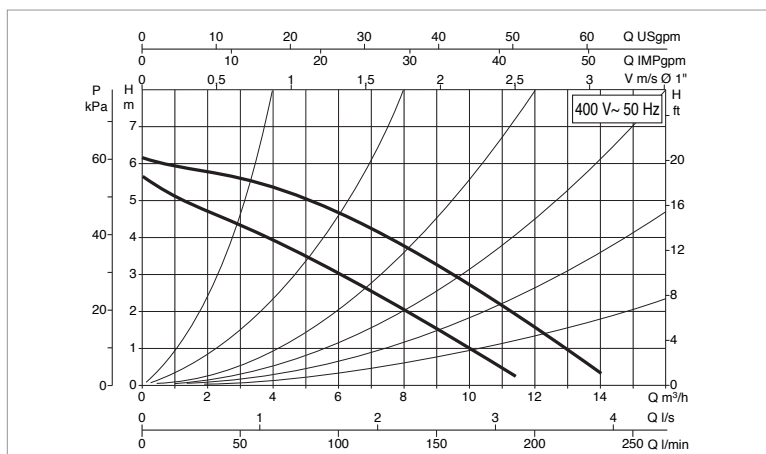
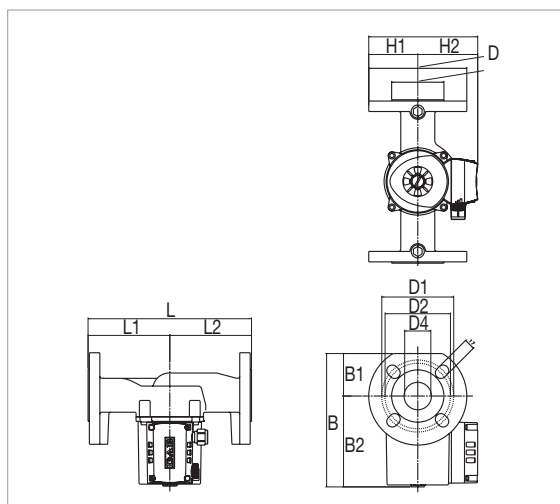

The performance curves are based on kinematic viscosity values = 1 mm²/s and density equal to 1000 kg/m³. Curve tolerance according to ISO 9906.

MODEL	CENTRE DISTANCE mm	POWER INPUT 50 Hz	UNIONS ON REQUEST	ELECTRICAL DATA						MINIMUM SUCTION PRESSURE	
				SPEED	REV. 1/min	P1 MAX W	In A	CAPACITOR		t°	90°
B 56/250.40 T	250	3x400 V ~	DN 40	2	2708	291	0,6	-	-	m.c.a.	1,5
				1	2178	200	0,32				

MODEL	L	L1	L2	B	B1	B2	D	D1	D2	D3	D4	H	H1	H2	F	PACKING DIMENSIONS			VOLUME m ³	WEIGHT kg
																L	B	H		
B 56/250.40 T	250	125	125	204	65	139	150	110	100	80	40	167	75	92	DN40/PN10	302	202	283	0,013	9,2

B 80/250.40 M - HEATING, AIR CONDITIONING

Pumped liquid temperature range: from -10 °C to +110 °C - Maximum operating pressure: 10 bar (1000 kPa)

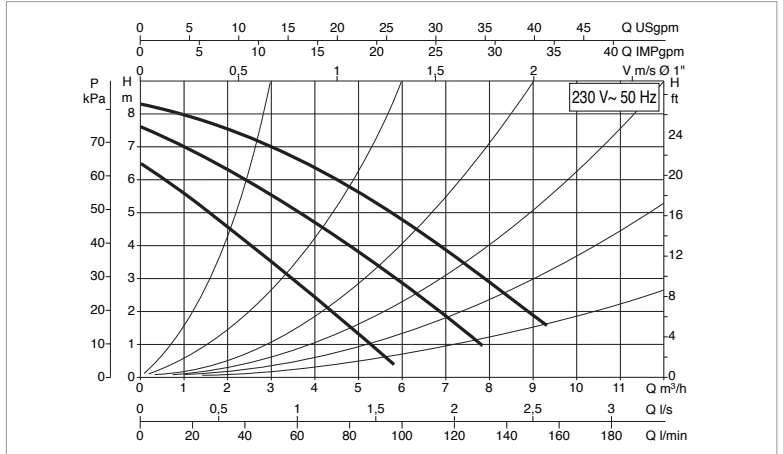
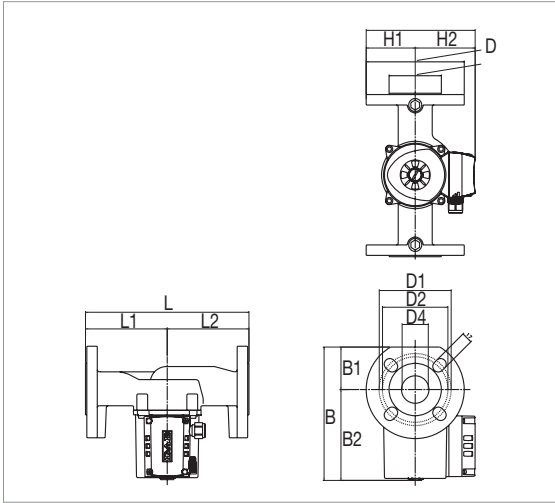

The performance curves are based on kinematic viscosity values = 1 mm²/s and density equal to 1000 kg/m³. Curve tolerance according to ISO 9906.

MODEL	CENTRE DISTANCE mm	POWER INPUT 50 Hz	UNIONS ON REQUEST	ELECTRICAL DATA						MINIMUM SUCTION PRESSURE	
				SPEED	REV. 1/min	P1 MAX W	In A	CAPACITOR		t°	90°
								µF	Vc		
B 80/250.40 M	250	1x230 V ~	DN 40	3	2683	256	1,12	7	400	m.c.a.	2,5
				2	2374	260	1,17				
				1	1688	218	1,00				

MODEL	L	L1	L2	B	B1	B2	D	D1	D2	D3	D4	H	H1	H2	F	PACKING DIMENSIONS			VOLUME m ³	WEIGHT kg
																L	B	H		
B 80/250.40 M	250	125	125	204	65	139	150	110	100	80	40	167	75	92	DN40/PN10	302	202	283	0,013	9,3

B 80/250.40 T - HEATING, AIR CONDITIONING

Pumped liquid temperature range: from -10 °C to +110 °C - Maximum operating pressure: 10 bar (1000 kPa)

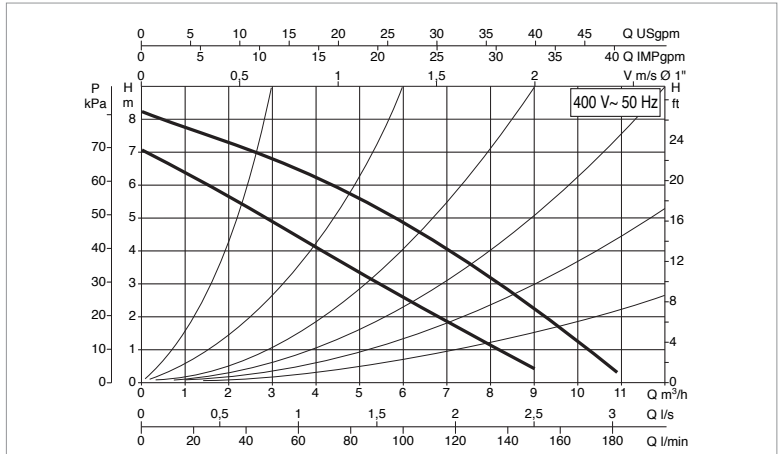
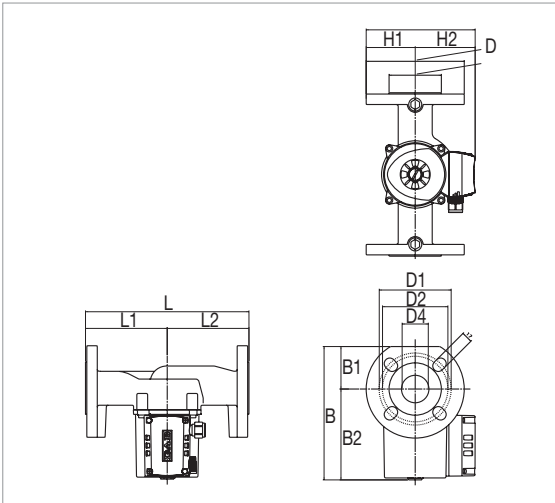

The performance curves are based on kinematic viscosity values = 1 mm²/s and density equal to 1000 kg/m³. Curve tolerance according to ISO 9906.

MODEL	CENTRE DISTANCE mm	POWER INPUT 50 Hz	UNIONS ON REQUEST	ELECTRICAL DATA						MINIMUM SUCTION PRESSURE	
				SPEED	REV. 1/min	P1 MAX W	In A	CAPACITOR		t°	90°
								µF	Vc		
B 80/250.40 T	250	3x400 V ~	DN 40	2	2724	271	0,57	-	-	m.c.a.	2,5
				1	2226	187	0,31				

MODEL	L	L1	L2	B	B1	B2	D	D1	D2	D3	D4	H	H1	H2	F	PACKING DIMENSIONS			VOLUME m ³	WEIGHT kg
																L	B	H		
B 80/250.40 T	250	125	125	204	65	139	150	110	100	80	40	167	75	92	DN40/PN10	302	202	283	0,013	9,3

B 110/250.40 M - HEATING, AIR CONDITIONING

Pumped liquid temperature range: from -10 °C to +110 °C - Maximum operating pressure: 10 bar (1000 kPa)

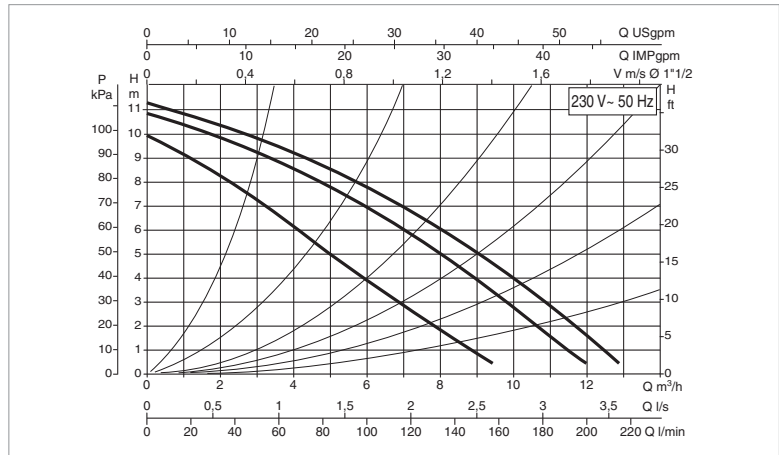
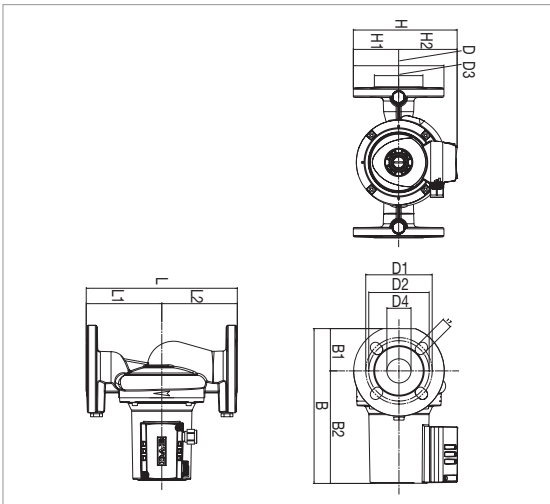

The performance curves are based on kinematic viscosity values = 1 mm²/s and density equal to 1000 kg/m³. Curve tolerance according to ISO 9906.

MODEL	CENTRE DISTANCE mm	POWER INPUT 50 Hz	UNIONS ON REQUEST	ELECTRICAL DATA						MINIMUM SUCTION PRESSURE	
				SPEED	REV. 1/min	P1 MAX W	In A	CAPACITOR		t°	90 °
								µF	Vc		
B 110/250.40 M	250	1x230 V ~	DN 40	3 2 1	2746 2552 2052	410 393 361	1,77 1,78 1,64	12 450	m.c.a.	2,5	

MODEL	L	L1	L2	B	B1	B2	D	D1	D2	D3	D4	H	H1	H2	F	PACKING DIMENSIONS			VOLUME m³	WEIGHT kg
																L	B	H		
B 110/250.40 M	250	125	125	256	70	186	150	110	100	80	40	172	75	97	DN40/PN10	302	202	283	0,013	9,2

B 110/250.40 T - HEATING, AIR CONDITIONING

Pumped liquid temperature range: from -10 °C to +110 °C - Maximum operating pressure: 10 bar (1000 kPa)

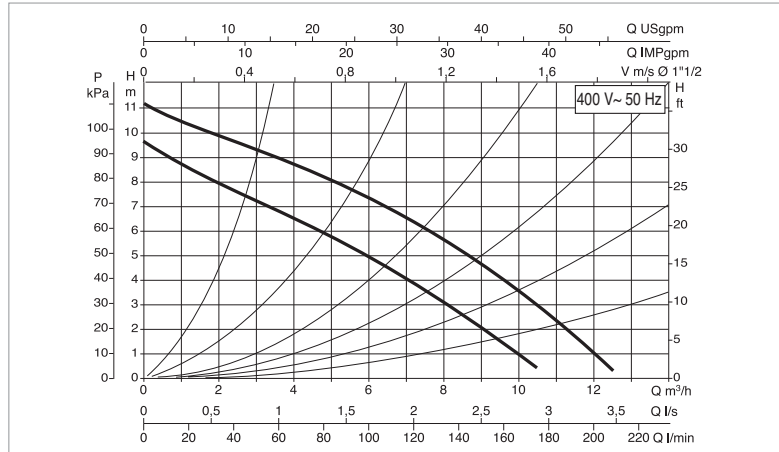
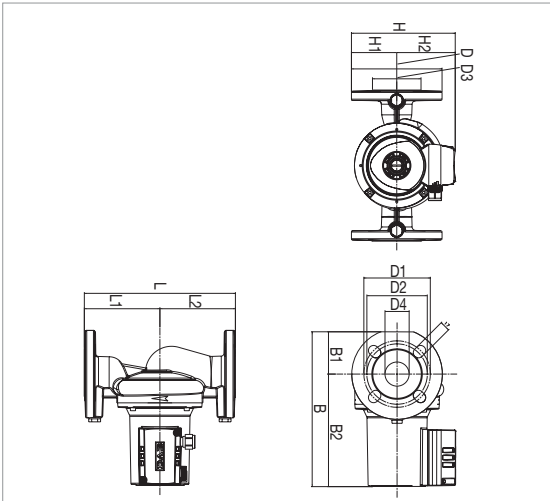

The performance curves are based on kinematic viscosity values = 1 mm²/s and density equal to 1000 kg/m³. Curve tolerance according to ISO 9906.

MODEL	CENTRE DISTANCE mm	POWER INPUT 50 Hz	UNIONS ON REQUEST	ELECTRICAL DATA						MINIMUM SUCTION PRESSURE	
				SPEED	REV. 1/min	P1 MAX W	In A	CAPACITOR		t°	90 °
								µF	Vc		
B 110/250.40 T	250	3x400 V ~	DN 40	2 1	2759 2341	403 289	0,90 0,48	- -	m.c.a.	2,5	

MODEL	L	L1	L2	B	B1	B2	D	D1	D2	D3	D4	H	H1	H2	F	PACKING DIMENSIONS			VOLUME m³	WEIGHT kg
																L	B	H		
B 110/250.40 T	250	125	125	256	70	186	150	110	100	80	40	168	75	93	DN40/PN10	302	202	283	0,013	9,3

D 50/250.40 M - HEATING, AIR CONDITIONING

Pumped liquid temperature range: from -10 °C to +110 °C - Maximum operating pressure: 10 bar (1000 kPa)

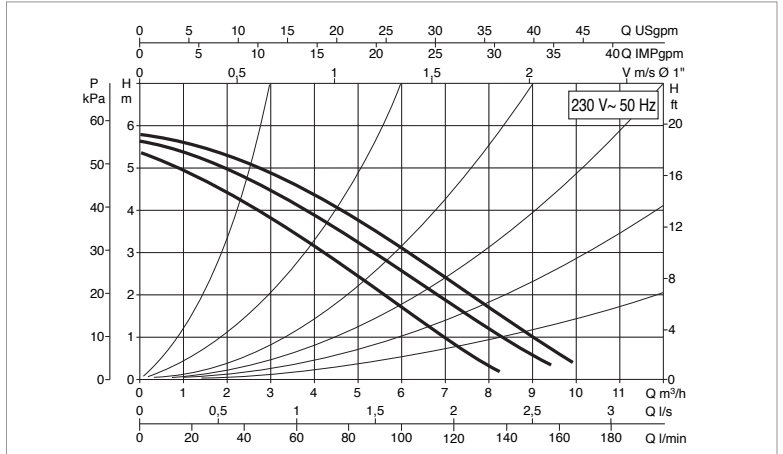
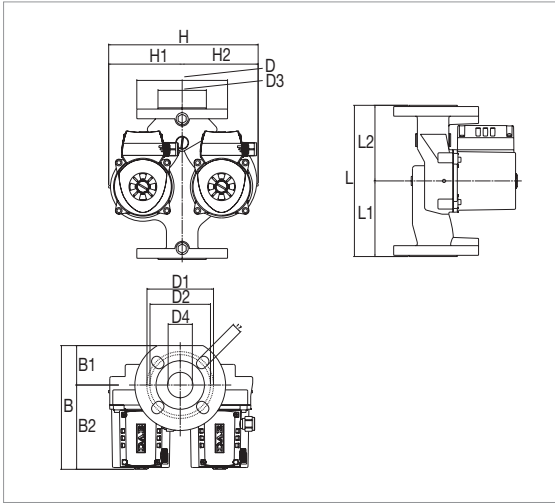

The performance curves are based on kinematic viscosity values = 1 mm²/s and density equal to 1000 kg/m³. Curve tolerance according to ISO 9906.

MODEL	CENTRE DISTANCE mm	POWER INPUT 50 Hz	UNIONS ON REQUEST	ELECTRICAL DATA						MINIMUM SUCTION PRESSURE	
				SPEED	REV. 1/min	P1 MAX W	In A	CAPACITOR		t°	90°
D 50/250.40 M	250	1x230 V ~	DN 40 - PN 10	3	2766	195	0,95	4	400	m.c.a.	1,5
				2	2616	194	0,95				
				1	2215	180	0,85				

MODEL	L	L1	L2	B	B1	B2	D	D1	D2	D3	D4	H	H1	H2	F	PACKING DIMENSIONS			VOLUME m³	WEIGHT kg
																L	B	H		
D 50/250.40 M	250	125	125	204	65	139	150	110	100	80	40	247	122	126	DN40/PN10	335	298	283	0,018	15,3

D 50/250.40 T - HEATING, AIR CONDITIONING

Pumped liquid temperature range: from -10 °C to +110 °C - Maximum operating pressure: 10 bar (1000 kPa)

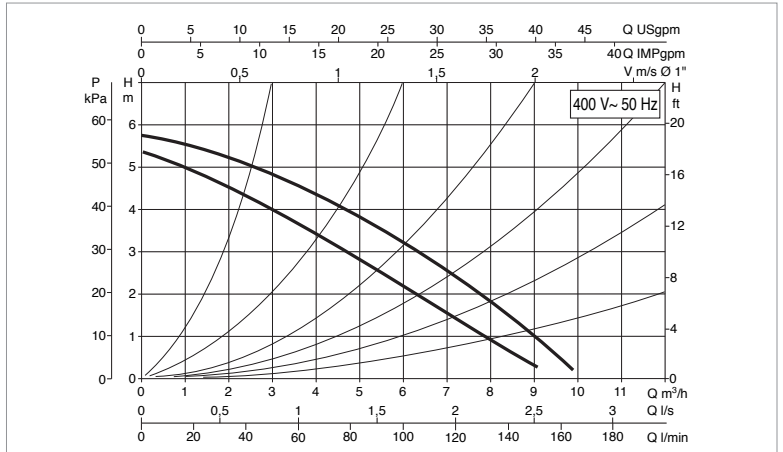
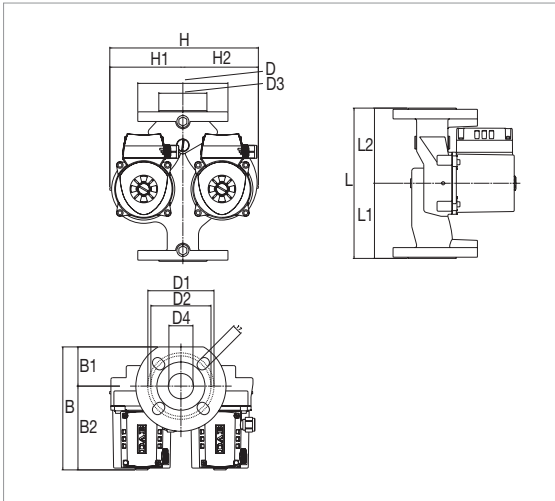

The performance curves are based on kinematic viscosity values = 1 mm²/s and density equal to 1000 kg/m³. Curve tolerance according to ISO 9906.

MODEL	CENTRE DISTANCE mm	POWER INPUT 50 Hz	UNIONS ON REQUEST	ELECTRICAL DATA						MINIMUM SUCTION PRESSURE	
				SPEED	REV. 1/min	P1 MAX W	In A	CAPACITOR		t°	90°
D 50/250.40 T	250	3x400 V ~	DN 40 - PN 10	2	2838	201	0,50	-	-	m.c.a.	1,5
				1	2520	129	0,23				

MODEL	L	L1	L2	B	B1	B2	D	D1	D2	D3	D4	H	H1	H2	F	PACKING DIMENSIONS			VOLUME m³	WEIGHT kg
																L	B	H		
D 50/250.40 T	250	125	125	204	65	139	150	110	100	80	40	247	122	126	DN40/PN10	335	298	283	0,018	15,8

D 56/250.40 M - HEATING, AIR CONDITIONING

Pumped liquid temperature range: from -10 °C to +110 °C - Maximum operating pressure: 10 bar (1000 kPa)

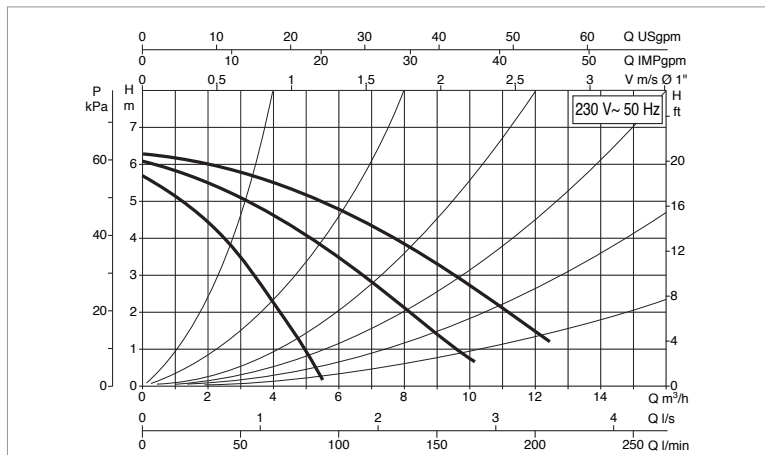
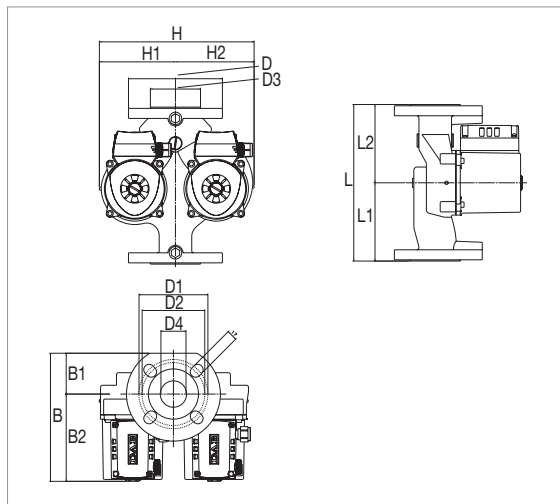

The performance curves are based on kinematic viscosity values = 1 mm²/s and density equal to 1000 kg/m³. Curve tolerance according to ISO 9906.

MODEL	CENTRE DISTANCE mm	POWER INPUT 50 Hz	UNIONS ON REQUEST	ELECTRICAL DATA						MINIMUM SUCTION PRESSURE	
				SPEED	REV. 1/min	P1 MAX W	In A	CAPACITOR		t°	90°
D 56/250.40 M	250	1x230 V ~	DN 40 - PN 10	3	2658	271	1,18	7	400	m.c.a.	1,5
				2	2117	294	1,32				
				1	1394	224	1,00				

MODEL	L	L1	L2	B	B1	B2	D	D1	D2	D3	D4	H	H1	H2	F	PACKING DIMENSIONS			VOLUME m³	WEIGHT kg
																L	B	H		
D 56/250.40 M	250	125	125	204	65	139	150	110	100	80	40	247	122	126	DN40/PN10	355	298	283	0,018	15,8

D 56/250.40 T - HEATING, AIR CONDITIONING

Pumped liquid temperature range: from -10 °C to +110 °C - Maximum operating pressure: 10 bar (1000 kPa)

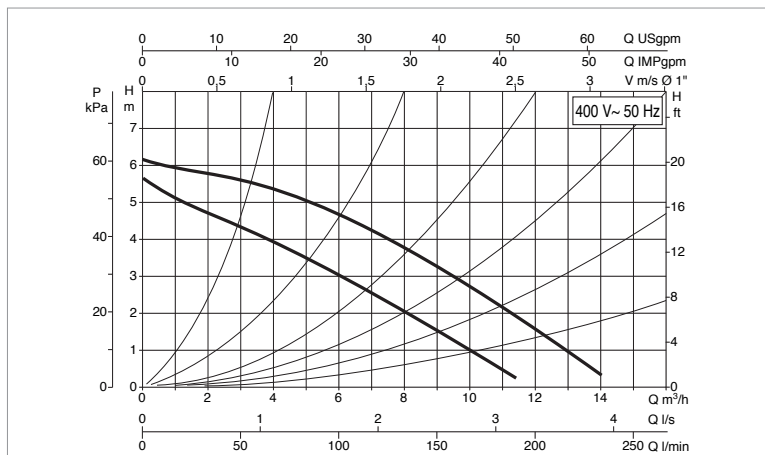
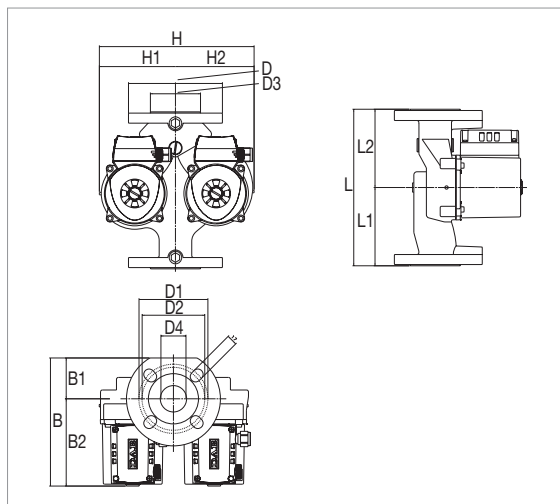

The performance curves are based on kinematic viscosity values = 1 mm²/s and density equal to 1000 kg/m³. Curve tolerance according to ISO 9906.

MODEL	CENTRE DISTANCE mm	POWER INPUT 50 Hz	UNIONS ON REQUEST	ELECTRICAL DATA						MINIMUM SUCTION PRESSURE	
				SPEED	REV. 1/min	P1 MAX W	In A	CAPACITOR		t°	90°
D 56/250.40 T	250	3x400 V ~	DN 40 - PN 10	2	2708	291	0,60	-	-	m.c.a.	1,5
				1	2178	200	0,33				

MODEL	L	L1	L2	B	B1	B2	D	D1	D2	D3	D4	H	H1	H2	F	PACKING DIMENSIONS			VOLUME m³	WEIGHT kg
																L	B	H		
D 56/250.40 T	250	125	125	204	65	139	150	110	100	80	40	247	122	126	DN40/PN10	335	298	283	0,018	15,4

D 80/250.40 M - HEATING, AIR CONDITIONING

Pumped liquid temperature range: from -10 °C to +110 °C - Maximum operating pressure: 10 bar (1000 kPa)

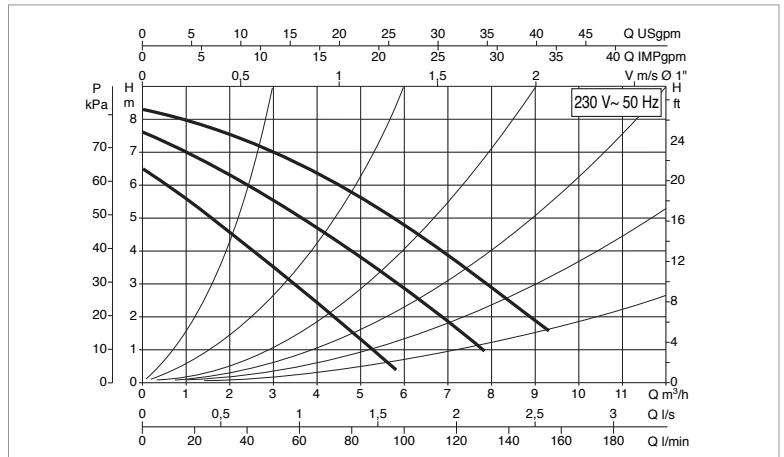
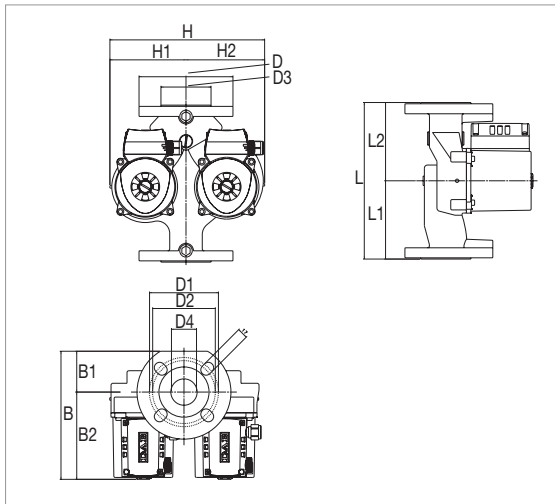

The performance curves are based on kinematic viscosity values = 1 mm²/s and density equal to 1000 kg/m³. Curve tolerance according to ISO 9906.

MODEL	CENTRE DISTANCE mm	POWER INPUT 50 Hz	UNIONS ON REQUEST	ELECTRICAL DATA						MINIMUM SUCTION PRESSURE	
				SPEED	REV. 1/min	P1 MAX W	In A	CAPACITOR		t°	90 °
D 80/250.40 M	250	1x230 V ~	DN 40 - PN 10	3	2683	256	1,12	7	400	m.c.a.	2,5
				2	2374	260	1,17				
				1	1688	218	1,00				

MODEL	L	L1	L2	B	B1	B2	D	D1	D2	D3	D4	H	H1	H2	F	PACKING DIMENSIONS			VOLUME m³	WEIGHT kg
																L	B	H		
D 80/250.40 M	250	125	125	204	65	139	150	110	100	80	40	247	122	126	DN40/PN10	355	298	283	0,018	15,8

D 80/250.40 T - HEATING, AIR CONDITIONING

Pumped liquid temperature range: from -10 °C to +110 °C - Maximum operating pressure: 10 bar (1000 kPa)

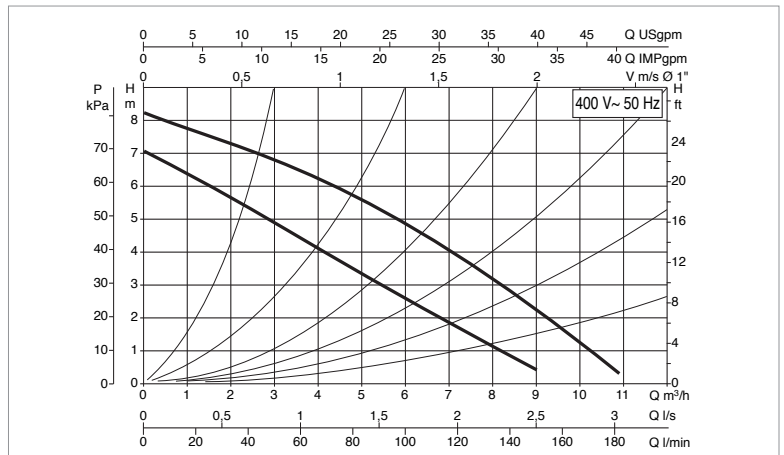
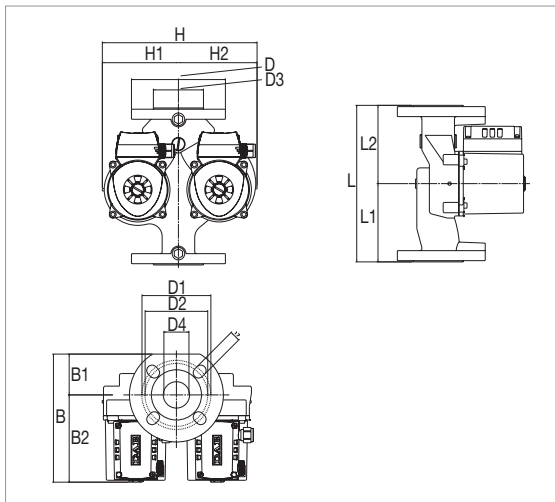

The performance curves are based on kinematic viscosity values = 1 mm²/s and density equal to 1000 kg/m³. Curve tolerance according to ISO 9906.

MODEL	CENTRE DISTANCE mm	POWER INPUT 50 Hz	UNIONS ON REQUEST	ELECTRICAL DATA						MINIMUM SUCTION PRESSURE	
				SPEED	REV. 1/min	P1 MAX W	In A	CAPACITOR		t°	90 °
D 80/250.40 T	250	3x400 V ~	DN 40 - PN 10	2	2724	271	0,57	-	-	m.c.a.	2,5
				1	2226	187	0,31				

MODEL	L	L1	L2	B	B1	B2	D	D1	D2	D3	D4	H	H1	H2	F	PACKING DIMENSIONS			VOLUME m³	WEIGHT kg
																L	B	H		
D 80/250.40 T	250	125	125	204	65	139	150	110	100	80	40	247	122	126	DN40/PN10	335	298	283	0,018	15,8

D 110/250.40 M - HEATING, AIR CONDITIONING

Pumped liquid temperature range: from -10 °C to +110 °C - Maximum operating pressure: 10 bar (1000 kPa)

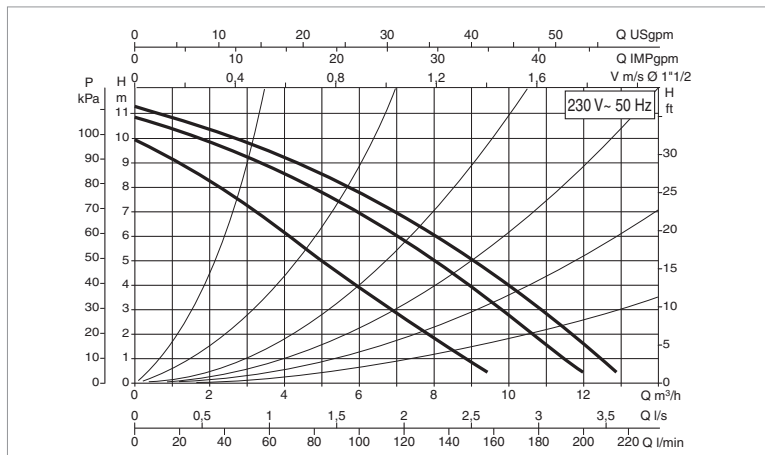
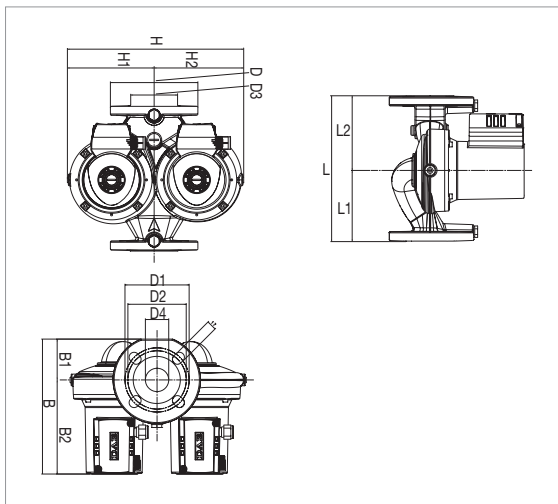

The performance curves are based on kinematic viscosity values = 1 mm²/s and density equal to 1000 kg/m³. Curve tolerance according to ISO 9906.

MODEL	CENTRE DISTANCE mm	POWER INPUT 50 Hz	UNIONS ON REQUEST	ELECTRICAL DATA						MINIMUM SUCTION PRESSURE	
				SPEED	REV. 1/min	P1 MAX W	In A	CAPACITOR		t°	90 °
D 110/250.40 M	250	1x230 V ~	DN 40 - PN 10	3	2746	410	1,77	12	450	m.c.a.	2,5
				2	2552	393	1,78				
				1	2052	361	1,64				

MODEL	L	L1	L2	B	B1	B2	D	D1	D2	D3	D4	H	H1	H2	F	PACKING DIMENSIONS			VOLUME m³	WEIGHT kg
																L	B	H		
D 110/250.40 M	250	122	128	231	70	161	150	110	100	80	40	302	149	154	DN40/PN10	355	298	283	0,018	16

D 110/250.40 T - HEATING, AIR CONDITIONING

Pumped liquid temperature range: from -10 °C to +110 °C - Maximum operating pressure: 10 bar (1000 kPa)

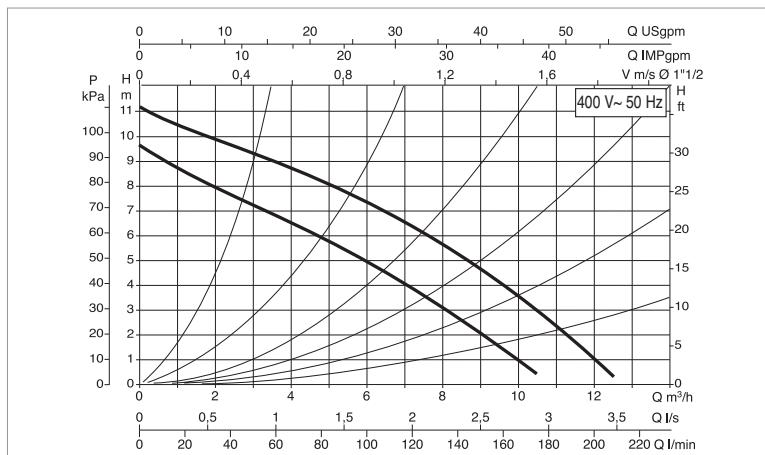
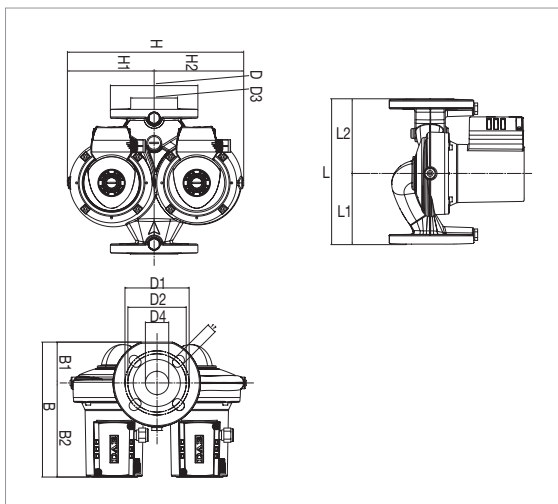

The performance curves are based on kinematic viscosity values = 1 mm²/s and density equal to 1000 kg/m³. Curve tolerance according to ISO 9906.

MODEL	CENTRE DISTANCE mm	POWER INPUT 50 Hz	UNIONS ON REQUEST	ELECTRICAL DATA						MINIMUM SUCTION PRESSURE	
				SPEED	REV. 1/min	P1 MAX W	In A	CAPACITOR		t°	90 °
D 110/250.40 T	250	3x400 V ~	DN 40 - PN 10	2	2759	403	0,90	-	-	m.c.a.	2,5
				1	2341	289	0,48				

MODEL	L	L1	L2	B	B1	B2	D	D1	D2	D3	D4	H	H1	H2	F	PACKING DIMENSIONS			VOLUME m³	WEIGHT kg
																L	B	H		
D 110/250.40 T	250	122	128	231	70	161	150	110	100	80	40	302	149	154	DN40/PN10	355	298	283	0,018	15,8